

KEEP THESE INSTRUCTIONS FOR FUTURE REFERENCE

# INSTALLATION, OPERATION, MAINTENANCE, AND PARTS INSTRUCTION MANUAL

# Solaronics

## COMPACT TUBE HEATER

US PATENTS: D378402, 5628303  
CANADIAN PATENT: 2,197,946

COMPACT  
GAS-FIRED  
LOW-INTENSITY  
INFRA-RED  
TUBE HEATER

- INDUSTRIAL
- COMMERCIAL
- VENTED
- UNVENTED
- RESIDENTIAL GARAGE

### FOR YOUR SAFETY

Do not store or use gasoline or other flammable vapors and liquids in the vicinity of this or any other appliance.

### FOR YOUR SAFETY

What to do if you smell gas:

1. Open windows.
2. Do not touch any electrical switches; do not use any phone in your building.
3. Do not try to light any appliance.
4. Extinguish any open flame.
5. Immediately call your gas supplier from a neighbor's phone. Follow the gas supplier's instructions.
6. If you cannot reach your gas supplier, call the fire department.

### ! WARNING !

Improper installation, adjustment, alteration, service, or maintenance can cause property damage, injury or death. Read the installation, operating and maintenance instructions thoroughly before installing or servicing this equipment.

A gas-fired appliance could expose you to substances in fuel or fuel combustion, which has been determined by the State of California to cause cancer, birth defects, or other reproductive harm. Contact factory for further information.

This manual must be carefully read and completely understood before installing, operating, or servicing this heater.

Installation and service must be performed by a qualified installer, service agency, or the gas supplier.

Contact factory for further information at 1-800-223-5335.

FOR EITHER INDOOR OR OUTDOOR INSTALLATION

## WARNINGS

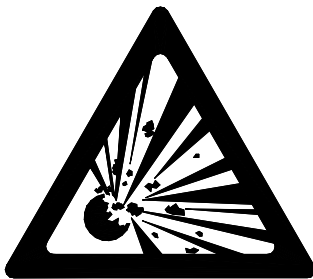
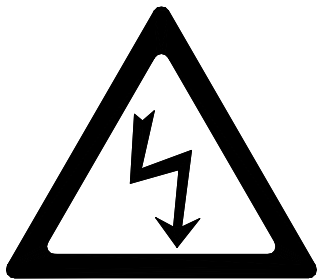

### ! WARNING !

#### FIRE OR EXPLOSION HAZARD

*Can cause property damage, severe injury or death.*

- Read manual carefully before installing, or servicing this equipment, or serious injury or death may result.
- Check minimum clearance to combustibles to make certain that heater is in a safe location. Combustible items located too close to the heater could cause a **serious fire hazard**. In storage areas, signs for maximum permissible stacking height to maintain clearance from the heater to combustible materials must be posted adjacent to the heater thermostats or in the absence of such thermostats in a conspicuous location.
- Operating the heater in an atmosphere containing combustible dust or flammable vapors is dangerous and may potentially result in injury or death.
- Heaters must be oriented in such a way as to maintain minimum clearances to vehicles parked underneath them.
- This heater is equipped with an automatic ignition and does not contain a pilot. **DO NOT** attempt to light the burner manually, this could result in serious personal injury or fire hazard.

### CAUTION

#### MECHANICAL HAZARD

- **DO NOT** use high pressure to test the gas pipes with the burner still attached. This will cause damage to the controls within the burner requiring them to be replaced.
- If heater is being operated in an atmosphere with a negative pressure or an atmosphere containing contaminants, an outside combustion air supply is required. Failure to provide outside combustion air may allow excessive heat to back up to the blower wheel and bearings severely shortening service life.
- Correct inlet pressure is important to efficiency and long lasting operation of the burner.
- Before servicing the burner or removing the cover panel, all electrical and gas supplies must be disconnected.
- Give consideration to construction such as partitions, storage racks, hoists, etc., and their relation to the installation of the heater.
- The heater must be installed and serviced **ONLY** by trained gas installation and service personnel.

### HAZARD INTENSITY LEVELS

DANGER: Failure to comply will result in severe personal injury or death and property damage.

WARNING: Failure to comply could result in severe personal injury or death and/or property damage.

CAUTION: Failure to comply could result in minor personal injury and/or property damage.

### IMPORTANT

Failure to follow these instructions may result in injury or property damage.

Compact Tube Heaters shall not be used in the following environments:

- |  |                           |
|--|---------------------------|
| • <u>Indoor living/sleeping quarters</u> | • Enclosed swimming pools |
| • Explosion-proof environments           | • Process heating.        |
| • Contaminated atmosphere applications   |                           |

NOTE: Contact factory if in any doubt.

## TABLE OF CONTENTS

<p>This instruction manual may not cover all details or variations in this equipment, or cover every possible situation to be met in connection with installation, operation, or maintenance. Should problems arise that are not covered sufficiently in these instructions, the purchaser is advised to contact the engineering department for further information.</p>	
<b>SECTION TITLES</b> – summary of information included	<b>PAGE</b>
<b>WARNINGS</b> – fire or explosion and mechanical hazards, hazard intensity levels and important safety information	2
<b>TABLE OF CONTENTS</b>	3
<b>INSTALLATION CODES</b> – general, aircraft hanger, public garage, parking structure and residential garage installations, material safety data sheets, UL listing and MEA approval	4
<b>CANADIAN ADDENDUM</b> – notes to installer, unvented heaters, aircraft hangars or public garages, combustion air and exhaust venting, and manual shut-off valve codes for use in Canada	5
<b>SPECIFICATIONS</b> – heater, control package/burner, combustion chamber/heat exchanger, and optional accessories	6
<b>OVERVIEW</b> – basic heater drawings and dimensions, warranty and certification limitations	7
<b>CLEARANCE TO COMBUSTIBLES</b> – warnings, and minimum distances from heaters to combustible materials	8
<b>MOUNTING CONSIDERATIONS</b> – includes minimum heater mounting heights and high elevation de-rating	9
<b>COMBUSTION AIR SUPPLY</b> – outdoor and indoor air supply instructions and illustrations	10
<b>EXHAUST VENTING FOR INDOOR INSTALLATION</b> – warning, direct outdoor venting, alternate and indirect indoor venting, exhaust vent distances and illustrations	11
<b>OUTDOOR INSTALLATION</b> – certification, requirements when exposed to weather, outdoor hood kit, venting and installation instructions	12
<b>SUSPENDED CEILING INSTALLATION</b> – additional instructions and illustrations	13
<b>SUSPENDING THE UNIT</b> – caution, mounting angles, instructions for using optional chain kits and illustrations	14
<b>GAS CONTROL FIELD INSTALLATION</b> – warnings, installation instructions with illustrations of components, location and orientation	15
<b>ELECTRICAL SUPPLY AND THERMOSTATIC CONTROL</b> – electrical supply, warnings, cautions, thermostatic control, thermostat installation notes and wiring diagram	16
<b>GAS SUPPLY AND GAS PRESSURE</b> – piping, pressure requirements, connection and control orientation illustrations	17
<b>STARTUP AND OPERATING INSTRUCTIONS</b> – initial startup procedures, warnings, safety notices, operating instructions and turn off procedures	18
<b>OPERATION AND WIRING</b> – sequence of operation, heater wiring ladder and interconnection diagrams	19
<b>MAINTENANCE</b> – warnings, recommended annual inspection and preventative procedures	20
<b>TROUBLESHOOTING</b> – symptoms, possible causes and corrective actions	21
<b>REPLACEMENT PARTS</b> – warning, parts list and gas conversion	22
<p>All rights reserved. No part of this work covered by the copyrights herein may be reproduced or copied by any means: graphic, electronic or mechanical, including photocopying, recording, taping, information storage and retrieval systems without written permission.</p>	

## INSTALLATION CODES

### ATTENTION

**Mount a copy of these instructions adjacent to heater and retain a copy for future reference.**

**A limited number of excerpts from various standards are outlined in the following instructions. However, the installer must be familiar with all of the various requirements and is responsible for compliance with the applicable codes.**

These gas-fired low-intensity infrared heaters are C.S.A. International design certified. If you have any questions call factory before attempting any installation work.

Gas-fired low-intensity infrared heaters are designed and manufactured in compliance with American National Standards Institute standard ANSI Z83.20-latest edition. Gas-fired low-intensity infrared heaters must be installed in accordance with applicable codes and only by a qualified agency. In the absence of local codes, installation must be in accordance with the National Fuel Gas Code ANSI 223.1 / NFPA 54-latest edition published by the National Fire Prevention Association (NFPA) and American Gas Association (AGA). All electrical work must conform to the National Electrical Code ANSI / NFPA 70-latest edition. The installation must meet the requirements of the Occupational Safety and Health Act (OSHA) which requires OSHA approved service and safety access to the systems after they are installed.

### GENERAL

All installations must be in accordance with ANSI Z223.1 / NFPA 54-latest edition National Fuel Gas Code especially:

SECTION 9.18 covers the general provisions for installing infrared heaters. Note the requirements for posting signs to specify the maximum permissible stacking height to maintain required clearances from heater to combustibles (9.18.2). Note also the exhaust requirement of 4 CFM/1000 BTUH (0.38 m<sup>3</sup>/minute/kW) when operating in the unvented mode (9.18.3.1). (See Canadian Addendum section herein.)

Exhaust openings for removing the flue products shall be above the level of the heater (9.18.3.2).

SECTION 8.1.11 part A states that in commercial garages "Gas utilization equipment installed in enclosed, basement, or underground parking structures shall be installed in accordance with Standard for Parking Structures, NFPA 88A."

SECTION 8.2 accessibility and clearance.

SECTION 8.3 air for combustion and ventilation.

### AIRCRAFT HANGARS

In aircraft hangars, the heaters must be installed in accordance with ANSI / NFPA 409-latest edition, chapter 5.

SECTION 5-4.5.2 specifies a clearance of ten (10) feet (3.05 m) to the bottom of the heater from the highest surface of the wings or engine enclosures of the highest aircraft which may be housed in the hangar.

SECTION 5-4.5.3 specifies a minimum clearance of eight (8) feet (2.44 m) from the floor to the heater in other sections of aircraft hangars such as offices or shops which may communicate with areas used for servicing and storage.

SECTION 5-4.5.4 specifies the heaters must be located so as to be protected from damage by aircraft or other objects such as cranes and moveable scaffolding. In addition, the heaters must be located so as to be accessible for servicing, adjustment, etc.

### PUBLIC GARAGES

In public garages, the heaters must be installed in accordance with National Fire Protection Association (NFPA) 88B-latest edition, Section 3-2.3.

SECTION 3-2.3.1 states that overhead heaters may be used provided they are located not less than eight (8) feet (2.44 m) above the floor and are installed in accordance with the conditions of their approval. (**WARNING:** Minimum clearances indicated on the heater's serial plate must be maintained for vehicles parked below the heater.)

SECTION 3-2.3.2 states that "a distance shall be maintained between the heater and its vents and any adjacent combustible material (which is part of the building or its contents) in conformance with NFPA 54, National Fuel Gas Code, Standard for the Installation of Oil Burning Equipment." (NFPA 54-latest edition).

### PARKING STRUCTURES

Approval requirements for parking structures are contained in NFPA 88A-latest edition and described in Section 4.2.

### RESIDENTIAL GARAGES

The Compact Tube Heater is approved for use in residential garages under A.G.A. Requirements for Residential Radiant Tube Heaters, No. 7-89.

### MATERIAL SAFETY DATA SHEETS

Gas-fired low-intensity infrared heaters comply with the US Superfund Amendments and Reauthorization ACT (SARA) Title III. No Material Safety Data Sheets are required.

### UL LISTING

These gas-fired low-intensity infrared heaters are design certified by C.S.A. International for compliance with the current American National Standard ANSI Z83.20. C.S.A. International is one of several approved agencies specializing in gas appliance design certification. Underwriters Laboratory (UL) listing is not required.

### MEA APPROVAL

These compact gas-fired low-intensity infrared tube heaters have been granted approval by New York City: MEA 321-98-E.

## CANADIAN ADDENDUM

### NOTES TO INSTALLER

These compact gas-fired low-intensity infrared tube heaters are C.S.A. International design certified for indoor and outdoor installation. They are designed and manufactured in compliance with *CSA Standard for Gas-Fired Low-Intensity Infrared Heaters*, CSA 2.34.

The installation must conform with local building codes or, in the absence of local codes, with the current *Canadian Natural Gas and Propane Installation Code*, CSA B149.1.

The electrical connection shall comply with the local codes or, in the absence of local codes, with the current *Canadian Electrical Code*, CAN/CSA C22.1, Part I and Part II, and *Electrical Features of Fuel Burning Equipment*, CAN/CSA C22.2 No. 3.

### UNVENTED HEATERS

The exhaust venting requirement is as follows:

- Natural gas requires 3 CFM per 1,000 BTUH (0.29 m<sup>3</sup>/minute/kW) and
- Propane gas requires 4 CFM per 1,000 BTUH (0.38 m<sup>3</sup>/minute/kW).

### AIRCRAFT HANGARS OR PUBLIC GARAGES

Gas-fired low-intensity infrared heaters are suitable for use when installed in accordance with the current *Canadian Natural Gas and Propane Installation Code*, CSA B149.1.

### COMBUSTION AIR AND EXHAUST VENTING

Vent terminal clearances shall be in accordance with the current *Canadian Natural Gas and Propane Installation Code*, CSA B149.1.

A horizontal vent shall NOT terminate:

- less than 6 feet (1.83 m) from a combustion air inlet or another appliance,
- less than 3 feet (0.91 m) from any other building opening or any gas service regulator, or
- less than 7 feet (2.13 m) above grade and
- directly above a gas utility meter or gas service regulator.

### MANUAL SHUT-OFF VALVES (FOR THE INCOMING GAS SUPPLY)

From the current *Canadian Natural Gas and Propane Installation Code*, CSA B149.1.

A manual shut-off valve shall be of the plug, ball, or eccentric type and it shall not be subjected to either a temperature or a pressure greater than its certified rating.

A readily accessible manual shut-off valve shall be installed to control the supply of gas to each appliance and the valve shall be located, in either the drop or riser, as close as possible to the valve train of a commercial and industrial type appliance.

## SPECIFICATIONS

### **COMPACT TUBE HEATER**

- CSA-International Design Certified
- Standards tested under: ANSI Z83.20-2001 / CSA 2.34-2001
- 20,000; 25,000 and 30,000 BTUH (5.9, 7.3, 8.8kW) multiple input ratings (3-position gas control)
- Natural or LP/Propane gas
- Minimum inlet pressure: 7" (18cm) W.C. Natural gas; 11" (28cm) W.C. LP/Propane gas.
- Maximum inlet pressure: 10.5" (27cm) W.C. Natural gas; 13" (33cm) W.C. LP/Propane gas.
- Serpentine shaped heat exchanger tube.
- 0.024" (0.61mm) highly polished stainless steel reflector
- Exhaust may be vented or unvented
- 20 feet (6.1m) maximum linear (straight) length of exhaust vent piping allowable (not included)
- Dry exhaust – no condensation of flue gases during steady state operating conditions
- Indoor or outdoor combustion air
- 15 feet (4.6m) maximum linear (straight) length of combustion air piping allowable (not included)
- Screened inlet air opening
- Direct spark ignition – 100% safety shut-off
- Intermittent blower with pre-purge and post-purge cycles
- Burner observation port
- Simple chain hanging arrangement
- Basic heater unit weight = 101 pounds (46kg)
- One (1) year limited warranty

### **CONTROL PACKAGE / BURNER**

- 120 VAC – 60 Hertz – 1 Phase, 3 prong electrical power cord set – 3 feet (91cm) long
- Maximum amp draw: 0.60 amps @ 120 VAC/ 60 Hertz/ 1 Phase (0.60 amp. replaceable panel fuse)
- Electronic flame monitoring for safety
- 120 VAC – 60 Hertz – 1 Phase blower motor; thermally protected
- Pre-purge time: 30 seconds
- Post-purge time: 5 minutes
- Two (2) air flow switches for combustion safety
- Fixed combustion air opening
- 24 VAC – 60 Hertz – 1 Phase thermostatic control
- External terminal board for easy field wiring of thermostat
- 3/8" MPT gas inlet

### **COMBUSTION CHAMBER / HEAT EXCHANGER**

- 2.75" (70mm) O.D. serpentine shaped tubing – 15 linear foot (4.6m) equivalent
- 14 gauge (0.08") (2mm) alumina-therm steel – 1.864 pounds per linear foot (2.774kg/m lineal)
- 0.72 square feet of radiant surface per linear foot (0.22m<sup>2</sup> of radiant surface per lineal meter)
- Wave formed turbulator for increased efficiency

### **OPTIONAL ACCESSORIES**

- 1/2" (13mm) square mesh decorative aluminum grille
- 50-foot (15.2m) length of 1/0 double loop chain and eight (8) "S" hooks for hanging
- 3" (76mm) piping and vent cap for indoor or outdoor venting (thru-the-wall or roof)
- RTV adhesive sealant for exhaust vent pipe joints
- 3" (76mm) ducting and inlet air cap for outdoor combustion air (thru-the-wall or roof)
- 3/8" NPT x 1/2" NPT flexible hose gas connector; stainless steel; 24" (61cm) long; 1/2 PSI (3.5kps) maximum pressure; comes with 1/2" NPT manual shut-off cock
- 24 VAC room thermostat & 35 feet (10.7m) thermostat wire; 40° to 80°F (4 – 27°C) range
- 24 VAC programmable night setback thermostat kit

## OVERVIEW

### BASIC HEATER DRAWINGS AND DIMENSIONS

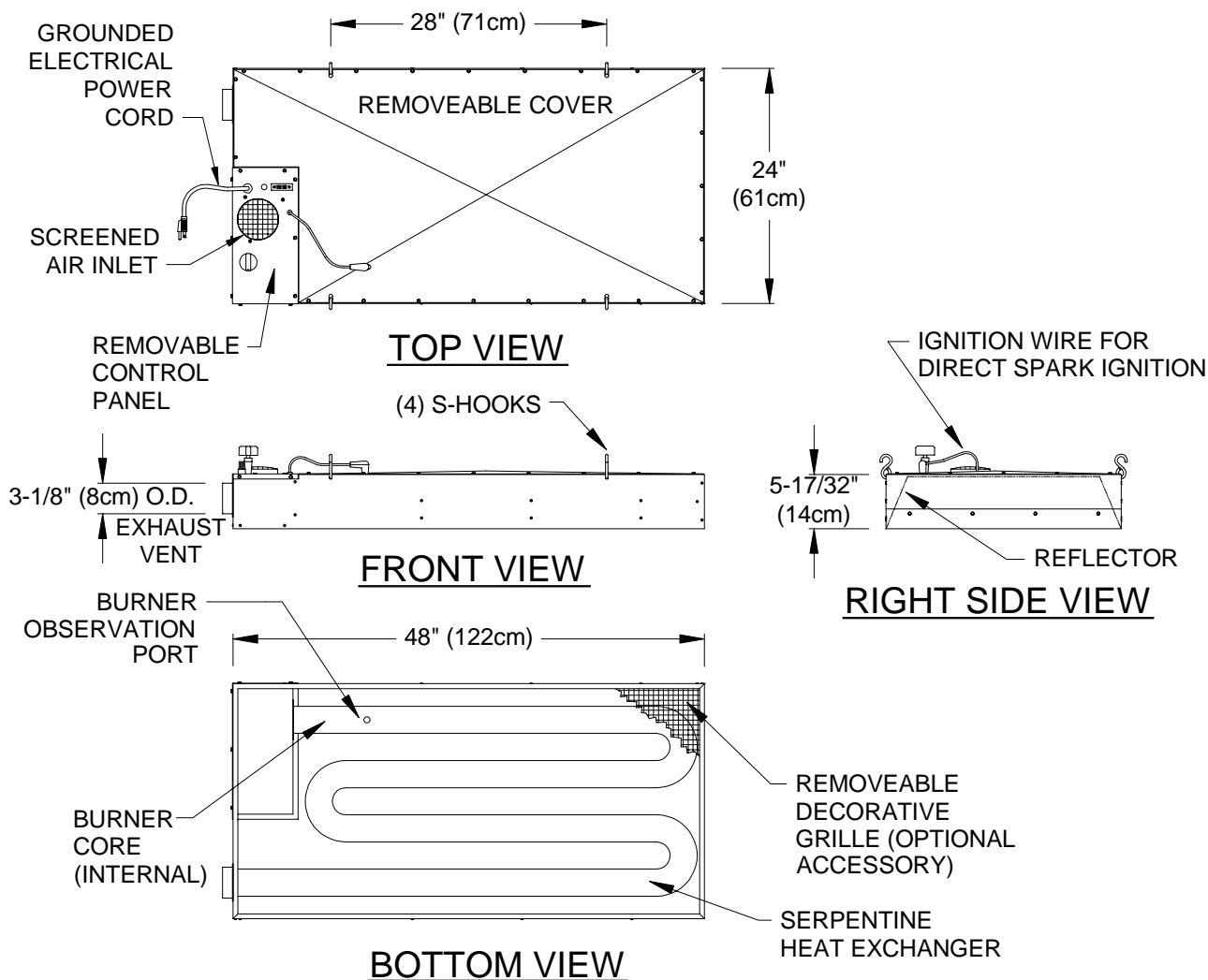

### WARRANTY AND CERTIFICATION LIMITATIONS

#### INSTALLATIONS OTHER THAN SPACE HEATING

- The Compact Tube Heater is designed for use as a space heater. Use for process heating applications VOIDS the warranty and CSA design certification.

#### WARRANTY VOID IF UNIT IS...

- Used in atmospheres containing flammable vapors or atmospheres containing chlorinated or halogenated hydrocarbons.
- Installed without proper clearance to combustible materials or in a location where the heater controls can be subjected to ambient temperatures above 150°F (66°C) or below -40°F (-40 °C).
- Installed at angles other than those approved for the heater. (See SUSPENDING THE UNIT section.)
- Installed for other than space heating applications.
- Altered. Units are completely factory assembled and tested.

## CLEARANCE TO COMBUSTIBLES

<b>! WARNING !</b>		<b>! WARNING !</b>		<b>! WARNING !</b>	
<p>The minimum clearances as shown in the diagram below <b>MUST</b> be maintained from any vehicles parked below this heater. The radiant heat can damage painted surfaces.</p>		<p>Failure to comply with these clearances could result in fire, property damage, personal injury, and/or death. Supervise young children when in the same room as the heater.</p>		<p>The area in all directions surrounding the heater <b>MUST</b> be kept clear from combustible materials, and other flammable vapors and liquids.</p>	
<b>1</b>	<p>Minimum clearance specified below <b>MUST BE</b> maintained to combustible materials and any other material that may be damaged by temperatures of 90°F above (50°C above) ambient room temperature. The specified distance <b>MUST BE</b> maintained from the top surface of carpeting, tile, etc.</p>				
<b>2</b>	<p>Minimum clearance to combustibles are also specified on each heater's serial plate located next to the blower on the burner.</p>				
<b>3</b>	<p>According to section 9.18.2(3) of the National Fuel Gas Code, "In locations used for storage of combustible materials, signs shall be posted to specify the maximum permissible stacking height to maintain required clearances from the heater to combustibles." These signs must be posted either adjacent to the heater thermostat or in a conspicuous location.</p>				
<b>4</b>	<p><b>CHILDREN AND ADULTS SHOULD BE ALERTED TO THE HAZARDS OF HIGH SURFACE TEMPERATURES ON THE HEATER, AND SHOULD STAY AWAY TO AVOID BURNS OR CLOTHING IGNITION.</b></p>				
<b>5</b>	<p><b>CLOTHING OR OTHER FLAMMABLE MATERIALS SHOULD NEVER BE HUNG FROM THE HEATER, OR PLACED ON OR NEAR THE HEATER. CERTAIN MATERIALS OR ITEMS, WHEN STORED UNDER THE HEATER, WILL BE SUBJECTED TO RADIANT HEAT AND COULD BE SERIOUSLY DAMAGED.</b></p>				

### MINIMUM CLEARANCE TO COMBUSTIBLES

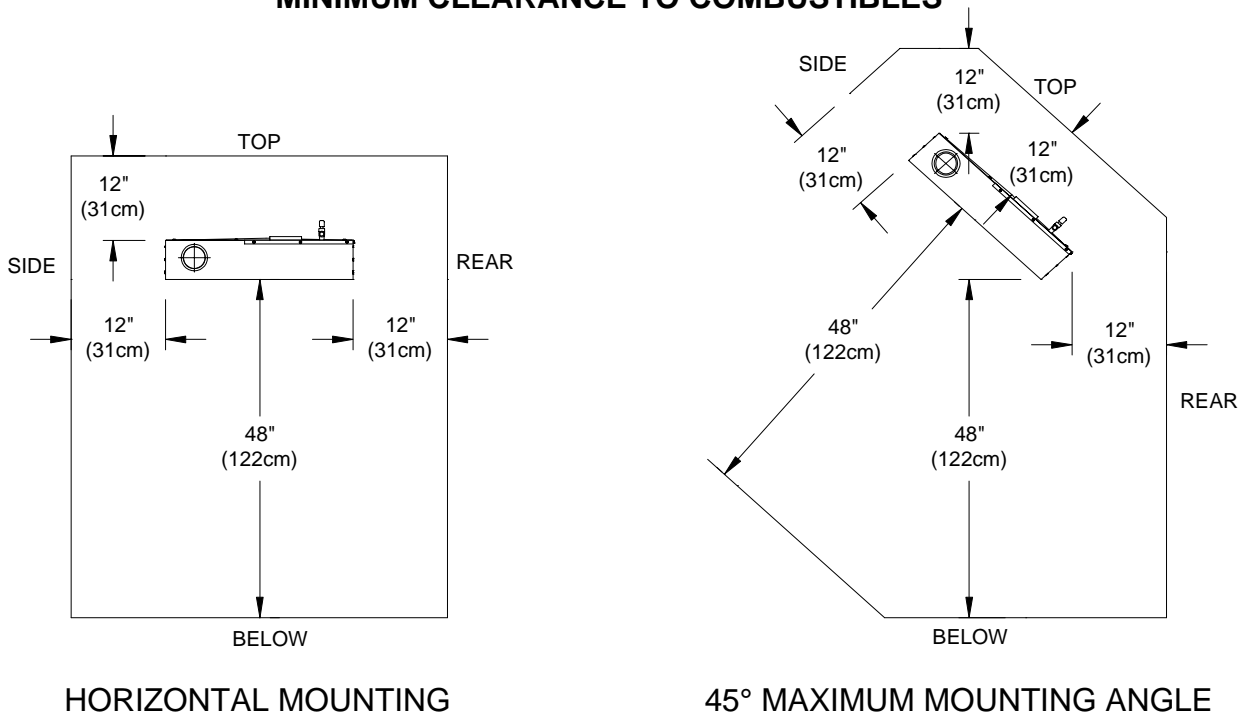

**MINIMUM MOUNTING HEIGHT:** Bottom of heater to floor: 8 feet (2.4m)

## MOUNTING CONSIDERATIONS

- Clearance to combustibles must be maintained at all times.
- In all cases, minimum installation height: 8 feet (2.4m) from floor/ground level.
- The heater must be controlled by a thermostat, timer, or other automatically operated device. On/off switches or direct wiring to a circuit breaker are not allowed. (See ELECTRICAL SUPPLY AND THERMOSTATIC CONTROL section.)
- Verify the buildings overhead structure has sufficient strength and proper suspension means to support the weight of the heater.
- Each suspension point must be capable of supporting a minimum of 200 pounds (91kg).
- Observe and verify all chains are plumb and vertical. A chain that is not plumb and vertical may cause damage to the heater.
- To maximize the heater's effectiveness to cover the space to be heated, it is recommended the heater be hung as high as possible and along an uncluttered wall to give the heater's reflector the widest possible "view".
- Leave enough space around the heater control package to permit future servicing.
- Choose a location allowing easy installation of the vent piping system.
- Allow for heater's movement during expansion and contraction through the operation cycle.
- Heaters shall **NOT** be installed in living/sleeping areas.

### HIGH ELEVATION

- If a heater is to be installed at a high elevation, in excess of 2000 feet (610m) above sea level, the BTUH (kW) input rating shall be derated at the rate of 4 percent for each 1000 feet (305m) above sea level in accordance with the National Fuel Gas Code.

# COMBUSTION AIR SUPPLY

## INSTRUCTIONS HERE ARE FOR A SINGLE COMPACT TUBE HEATER.

- Atmospheric air for combustion may come from either outdoors or indoors (within the building).
- Installation of combustion air supply must comply with the instructions, drawings, and installation notes provided in this section.
- Before the installation of any suspended heating system, careful consideration must be given to the combustion air arrangement when it is supplied thru-the-wall or thru-the-roof from the outdoors. CSA-International design certification is based on the following requirements:
  - **For all systems, total linear (straight) pipe run must not exceed 15 feet (4.6m) within the building.**
  - A 90° elbow is equivalent to 5 lineal feet (1.5m). No more than (2) two 90° elbows are permitted.
  - Any additional combustion air piping (not supplied) must be maximum 20 gauge (1.0mm), minimum 26 gauge (0.4mm) single wall non-corroding material 3 inches O.D. +0"/-0.031" (76.2mm +0/-0.8mm).
  - **The inlet air cap MUST be Simpson Dura-Vent brand and no substitutions are permitted.**
  - If all the above mentioned components are supplied by someone other than the heater manufacturer, they must be identical to those specified herein. NO SUBSTITUTES.

### OUTDOOR AIR SUPPLY

- In buildings contaminated with excessive dust or dirt, containing substances which when combined with flame and exhaust products result in corrosive gases, or those under a negative pressure, combustion air must be taken from outdoors.
- Outdoor air must be free of contaminants.
- When combustion air is supplied from outdoors, the heater must also be vented to the outdoors.
- Outdoor air supply may be accomplished by bringing air inside through piping from either the roof or wall as shown below.
- The inlet air cap must be located at least (3) three feet (91cm) away from any exhaust vent termination and in a manner preventing blockage by snow.
- If the inlet air cap is within (10) ten feet (3m) of a vertical exhaust vent terminal on a roof, the vertical exhaust vent terminal must be at least (12) twelve inches (31cm) higher than the inlet air cap.
- It may be necessary to insulate the inlet air supply piping to eliminate condensation from warm indoor air on the piping's exterior.

### INDOOR AIR SUPPLY

- When combustion air is to be taken from inside a tightly sealed or closed building, fresh air intake opening(s) from the outside must be installed to supply the burner with sufficient air for combustion.
- The opening(s) must be made so that for every 1,000 BTUH (293W) of the total input of all gas-fired equipment, one square inch (6.5cm<sup>2</sup>) (22cm<sup>2</sup>/kW) or more of free area opening is provided. Fresh air intake openings should direct air upward to prevent drafts at the floor.
- Total area required can be computed by dividing exhaust CFM by 500 feet per minute (dividing exhaust cubic meters per minute by 152 meters per minute).
- If combustion air is supplied from the space to be heated, it must be free of contaminants that may interfere with the proper and safe operation of the heater. Some contaminants like halogenated hydrocarbons or other corrosive elements may shorten the life of the heater.
- The heater inlet air opening must have 12" (31cm) clear space in all directions.

### GENERAL PARTS DESCRIPTION

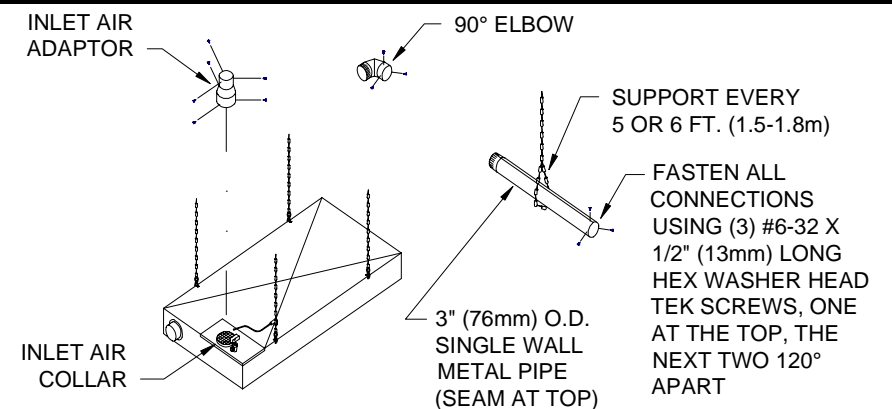

### THRU-THE-WALL

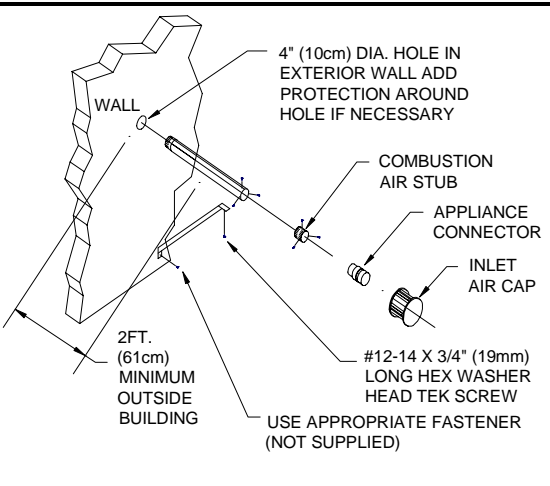

### THRU-THE-ROOF

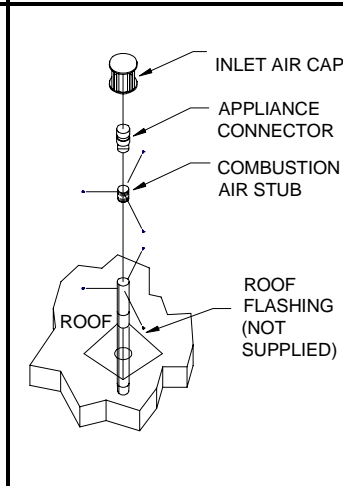

### IMPORTANT

- **DO NOT** use collapsible material such as dryer duct as a substitute for single wall galvanized or PVC pipe. It will restrict airflow to the burner causing improper operation.
- Inlet air piping must be well supported since additional stress may be encountered due to some expansion during heater operation.
- Substitution of any factory listed parts without prior written permission will void all warranties and design certification.
- Consult factory if trying to supply 2 or more heaters by a common inlet air pipe.

# EXHAUST VENTING FOR INDOOR INSTALLATION

## ! WARNING !

Improper exhaust venting can allow exhaust gases to collect inside a building leading to asphyxiation and death. The heater must be installed and serviced **ONLY** by trained gas installation and service personnel according to local or national installation codes.

### INSTRUCTIONS HERE ARE FOR A SINGLE COMPACT TUBE HEATER.

- **ALL heaters used for RESIDENTIAL purposes MUST be directly vented OUTDOORS; NO EXCEPTIONS!**
- Installation of exhaust venting must comply with the instructions, drawings, and installation notes provided in this section.

### DIRECT OUTDOOR VENTING

- A heater vented directly outdoors is classified as Category III by the National Fuel Gas Code.
- It may be vented through either the roof or wall. Before the installation of any suspended heating system, careful consideration must be given to the exhaust gas venting arrangement when passing thru-the-wall or thru-the-roof. CSA-International design certification is based on the following requirements.
- **For all systems, total linear (straight) pipe run must not exceed 20 feet (6.1m), and must be a minimum of 2.5 feet (76cm) long.**
- A 90° elbow is equivalent to 5 lineal feet (1.5m). No more than (2) two 90° elbows are permitted.
- Any additional exhaust vent piping (not supplied) must be maximum 20 gauge (1.0mm), minimum 26 gauge (0.4mm) single wall non-corroding material 3 inches O.D. +0"/-0.031" (76.2mm +0mm/-0.8mm), to fit properly from the exhaust end opening of the heater to the 3" (76mm) type B gas vent subassembly.
- **The exhaust vent cap MUST be Metalbestos brand double wall type B gas vent and no substitutions are permitted.**
- If all the above mentioned components are supplied by someone other than the heater manufacturer, they must be identical to those specified herein. **NO SUBSTITUTES.**
- Heater must not be vented in between buildings less than (10) ten feet (3m) apart or above public walkways, doors or windows.
- A vent termination must be located at least (3) three feet (91cm) away from any inlet air cap and in a manner preventing blockage by snow and protecting building materials from degradation by flue gases.
- Vent cap must be a minimum of (2) two feet (61cm) above or beyond the highest structure of surface within (10) ten feet (3m) of the vent.
- Allow 18" (46cm) clearance from single wall metal pipe to combustible materials throughout the entire length of exhaust vent piping.
- Where a single wall metal pipe passes through a wall/roof of combustible material, a minimum 2" (51mm) clearance non-combustible ventilated metal thimble (not supplied) **MUST** be installed in wall/roof at the point of passage.
- Use RTV silicone adhesive sealant liberally at all vent pipe joints.
- Use three (3) #6 sheet metal screws per vent pipe joint – starting at the top, 120° apart.
- 1-inch (25mm) thick pipe insulation wrapped around the single wall sheet metal pipe is recommended.
- Vent pipes must be well supported due to the extra stress that occurs during expansion of the unit when operating.

### INDIRECT INDOOR VENTING

- A heater that is vented indoors is classified as Category I by the National Fuel Gas Code. **NO INDOOR VENTING AT A RESIDENCE.**
- At least 4 CFM of exhaust per 1,000 BTUH (0.38m<sup>3</sup>/kW) **MUST** be provided. Supply and exhaust air must be provided by natural or mechanical means. For Canada see CANADIAN ADDENDUM section.
- For supply and exhaust air by natural means, fresh air/exhaust openings are required. Fresh air openings should be below the heater's air inlet. Exhaust openings **MUST** be located above the heaters.
- For supply air and exhaust ventilation by mechanical means, provisions **MUST** be made so the flow of gas to the heater is allowed **ONLY** when the mechanical exhaust is in operation.
- Combustion air **MUST NOT** be provided directly from outdoors to the inlet air collar on the burner.

### EXHAUST VENT DISTANCE FROM:

	BELOW Inches (cm)	BESIDE Inches (cm)	ABOVE Inches (cm)
Door	N/A	48 (122)	N/A
Window	48 (122)	12 (31)	N/A
Gravity Air Inlet	N/A	N/A	12 (31)
Forced Air Inlet Within 10 feet (3m)	N/A	N/A	36 (91)
Grade	N/A	N/A	12 (31)
Gas Meters & Electric Meters, Regulators & Relief Valves	N/A	48 (122)	N/A

### THRU-THE-WALL

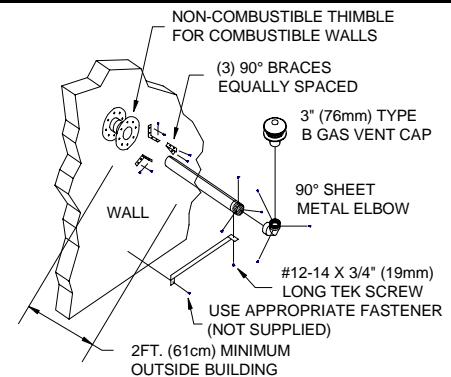

### THRU-THE ROOF

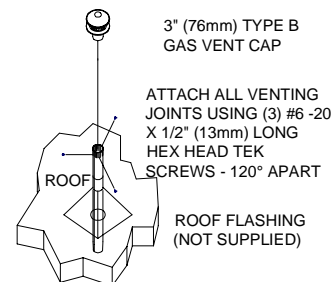

### INSIDE OF BUILDING

#### NO INDOOR VENTING AT A RESIDENCE

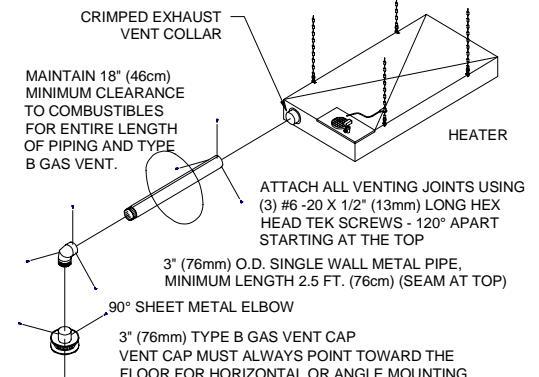

## OUTDOOR INSTALLATION

The Compact Tube Heater is CSA design certified for use outdoors. When the heater is exposed to the weather outdoors, the Outdoor Hood Kit (available separately) must be installed on the heater. In this case, failure to use, or substitution of any parts listed here, without prior written permission from the factory, will void CSA design certification and all warranties.

### OUTDOOR HOOD KIT

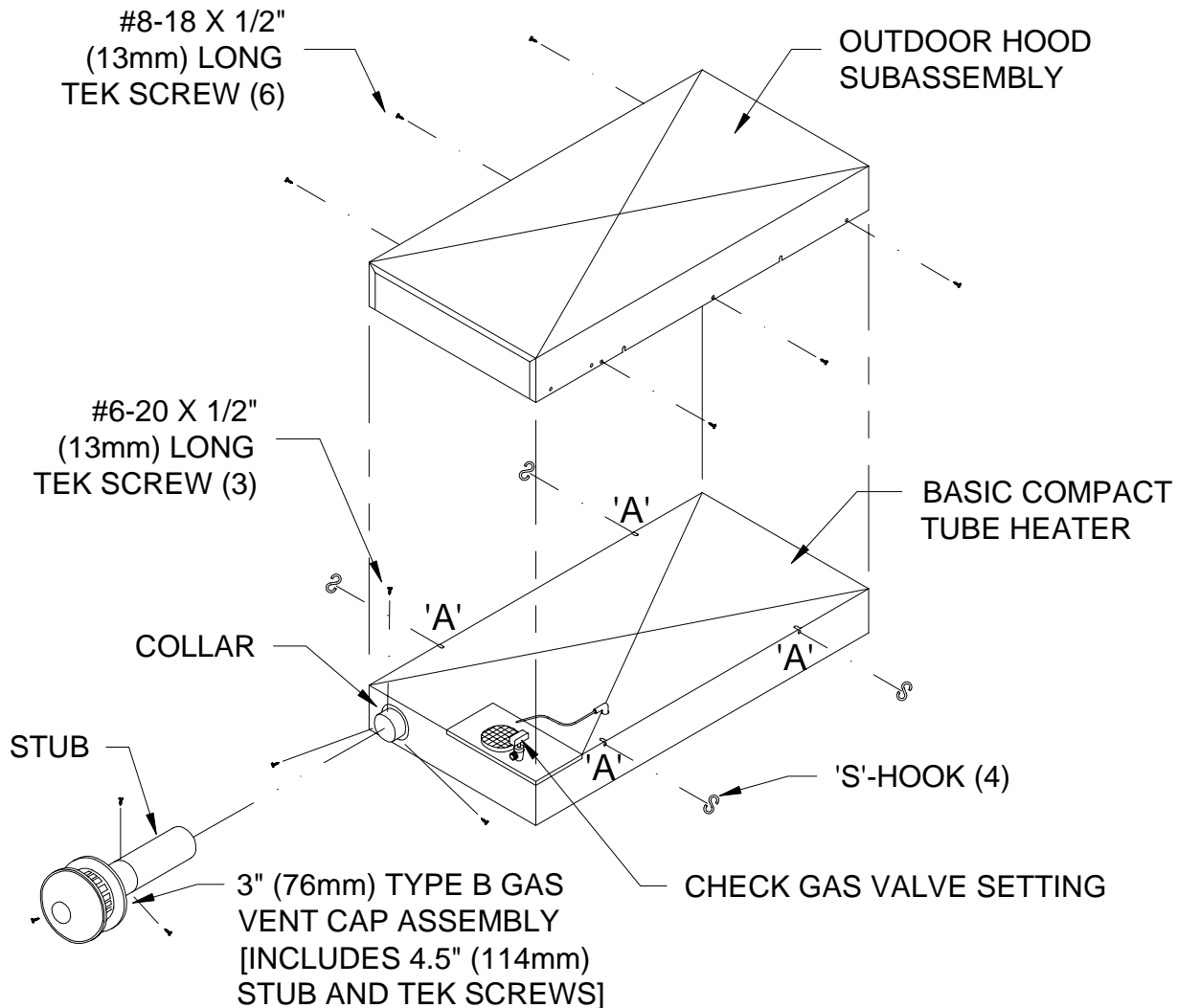

### OUTDOOR HOOD KIT INSTALLATION INSTRUCTIONS

1. Assemble 3" (76mm) type B gas vent cap assembly [3" (76mm) type B gas vent and exhaust vent stub 4.5" (114mm) long with (3) three #6-20 x 1/2" (13mm) Tek screws 120° apart].
2. Fasten cap subassembly to collar on heater with three (3) #6-20 x 1/2" (13mm) long Tek screws, 120° apart, starting at the top.
3. Turn the gas valve knob to desired setting – HIGH / MED / LOW.
4. Slip (4) four 'S'-hooks into holes at points labeled by 'A' as shown above.
5. Set the outdoor hood subassembly over the basic compact tube heater, aligning the slots with the 'S'-hooks and slide down for a snug fit.
6. Fasten outdoor hood subassembly to heater with (6) six #8-18 x 1/2" (13mm) long Tek screws.

## SUSPENDED CEILING INSTALLATION

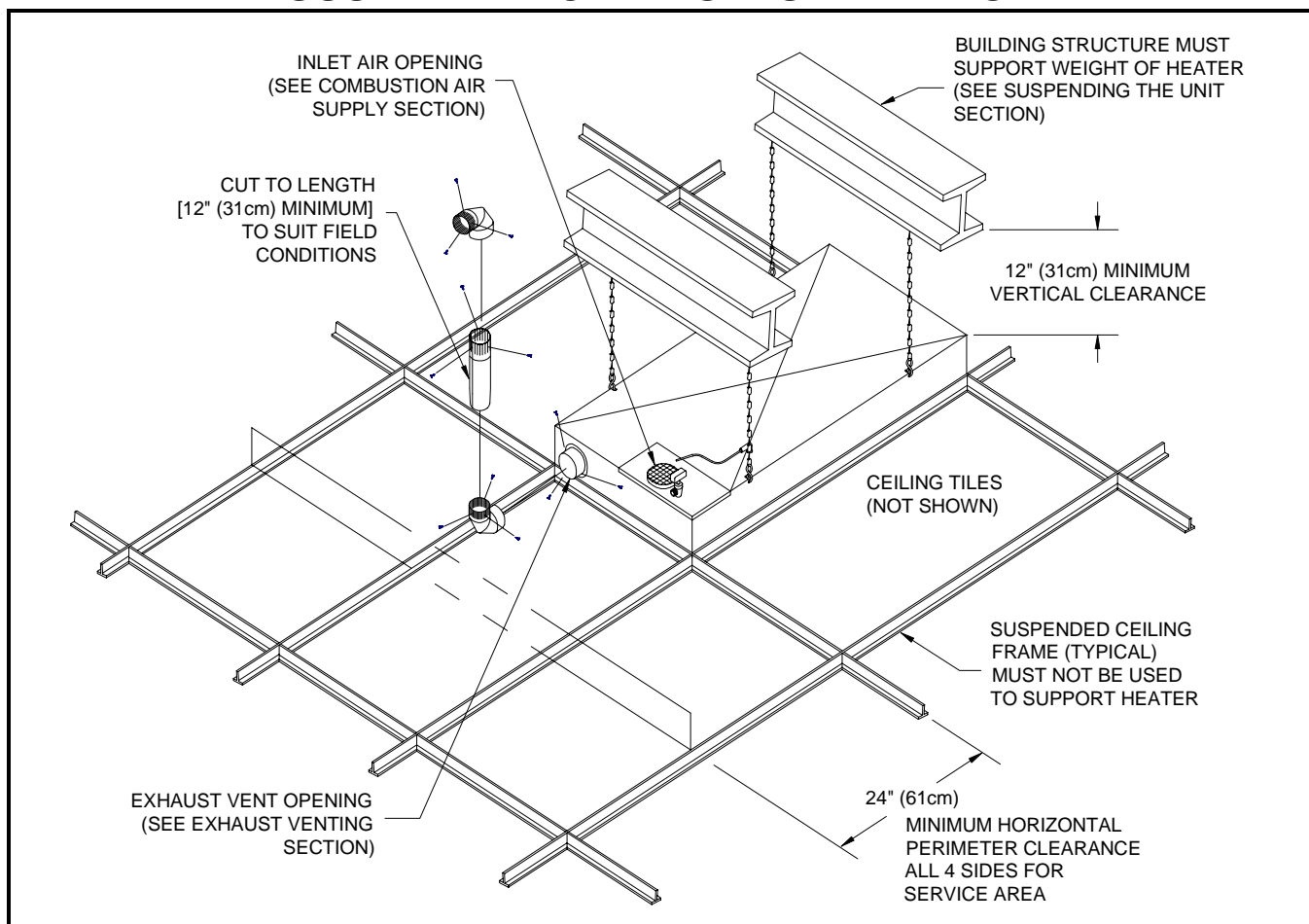

### ADDITIONAL INSTRUCTIONS FOR INSTALLING IN A SUSPENDED CEILING

These instructions may not cover all details or variations in this equipment, or cover every possible situation to be met in connection with installation, operation or maintenance. Should problems arise that are not covered sufficiently in these instructions, the purchaser is advised to contact the heater manufacturer's engineering department for further information.

1. The weight of the heater **MUST** be supported from the building's structure. **NEVER** rely on the suspended ceiling frame for support of the heater. See SUSPENDING THE UNIT section.
2. **NEVER** place the heater directly onto a regular ceiling tile since it would create an unsafe condition.
3. Verify the ceiling panels adjacent to each side of the heater and the exhaust vent piping are not combustible.
4. Verify the installation is acceptable to local authorities.
5. Combustion air **MUST ALWAYS** come from the outdoors. See COMBUSTION AIR SUPPLY section.
6. Exhaust venting **MUST ALWAYS** go to the outdoors. See EXHAUST VENTING section.
7. **DO NOT** run exhaust vent piping directly over ceiling panels, lighting fixtures, speakers, or anything else possibly affected by heat. **ALWAYS** COME OUT OF THE EXHAUST VENT OPENING WITH A 90-DEGREE ELBOW AND RUN VERTICALLY TO AVOID OVERHEATING POSSIBILITIES.
8. Particular consideration must be given to the clearance to combustibles in this type of installation. The clearance to combustibles will be the same as indicated in the CLEARANCE TO COMBUSTIBLES section.
9. Exhaust venting can be horizontal "thru-the-wall" or vertical "thru-the-roof".
10. Allow 24 inches (61cm) clearance around the perimeter of the heater for servicing and maintenance and to prevent overheating lighting fixtures, speakers, etc.
11. For all exhaust vent joints, use RTV sealant to prevent hot flue gas leakage into the building.
12. **DO NOT** run gas piping or electrical conduit over the top of the heater or exhaust vent piping.

Annual maintenance is important for safe and efficient heater operation. At the beginning of each heating season, wipe off all dust from the heater to avoid odor of dust burning. See MAINTENANCE section.

## SUSPENDING THE UNIT

- **CAUTION!** This unit weighs 101 pounds (46kg). Always use (2) two people when lifting or carrying the heater. See Hazard Intensity Levels on page 2.
- Before installing the heater, check the supporting structure to determine whether it has sufficient load carrying capacity to support the weight. The installer is responsible for safe suspension of the heater.
- If permissible by local code, it is recommended that these heaters be suspended with chain and "S" hook mounting. Chain with 200 pound (91kg) working load (#1/0 Tenso) is recommended. "S" hooks must be a minimum of 1/4" (6.3mm) diameter wire (#5 "S" hook) and must be closed after installation.
- If a heater is located in an aircraft hangar or near overhead doors, it should be rigidly mounted to prevent swinging.
- Under **NO** circumstances should either the gas supply line or electrical supply line to the heater be used to provide assistance in suspension.
- **DO NOT** run any gas or electric service lines above or below the heater or near the path of the flue products if heater is indirectly vented.

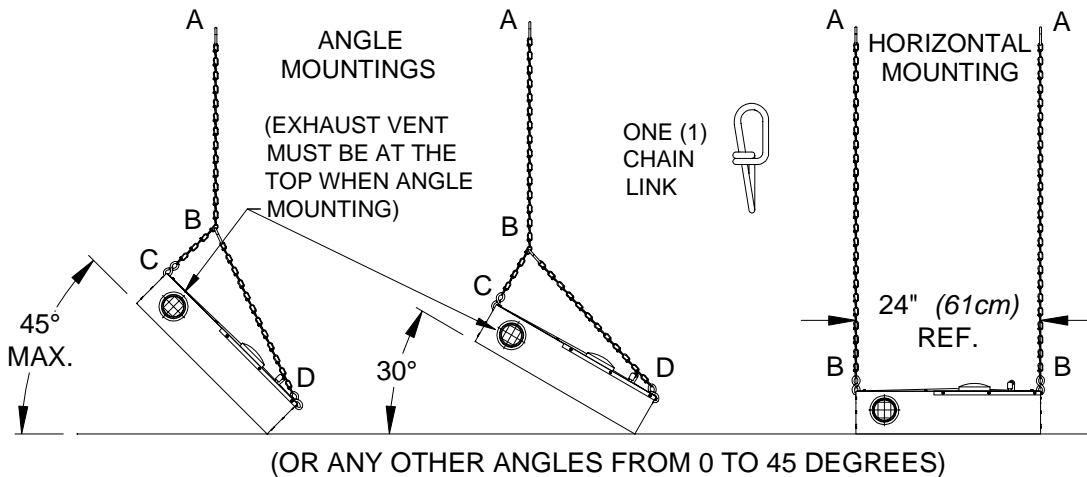

### HOLE HANGING PATTERN (ON TOP OF HEATER)

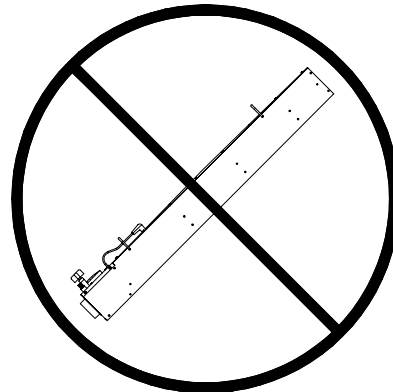
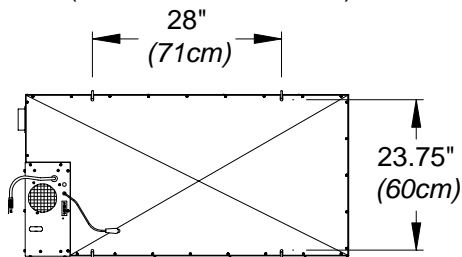

DO NOT ANGLE MOUNT THE HEATER  
ALONG THE (4) FOUR FOOT (122cm) SIDE!

### INSTRUCTIONS FOR USING OPTIONAL CHAIN KITS

1. Hang full length chains at desired height and attach to back of heater (C) with "S" hooks.
2. Attach one end of 11 inch (28cm) length of chains with "S" hooks to front of heater (D).
3. Place other end of chains with "S" hooks in chain link (B) on the full length chain.
4. Check degree of angle mounting. Adjust degree of mounting angle by moving "S" hooks at point (B).
5. Check to make sure the unit is level. Manually crimp all "S" hooks closed.

## GAS CONTROL FIELD INSTALLATION

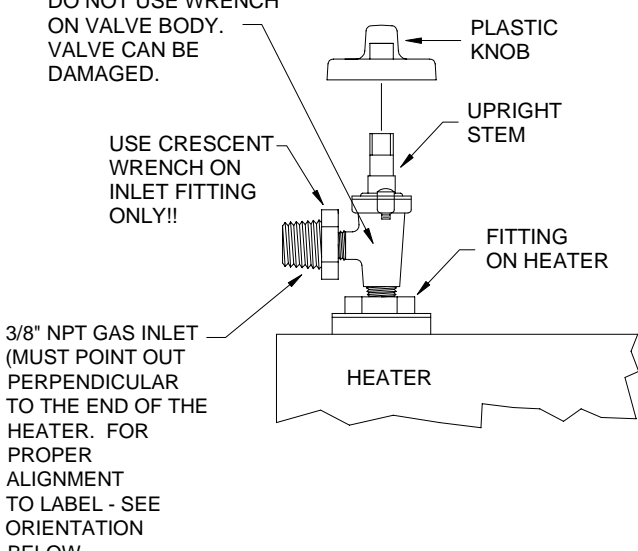
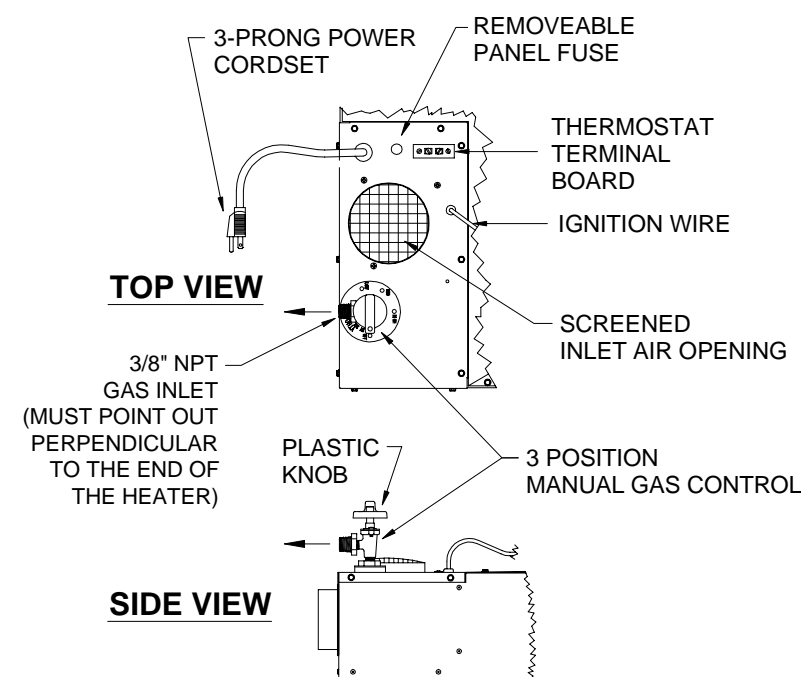
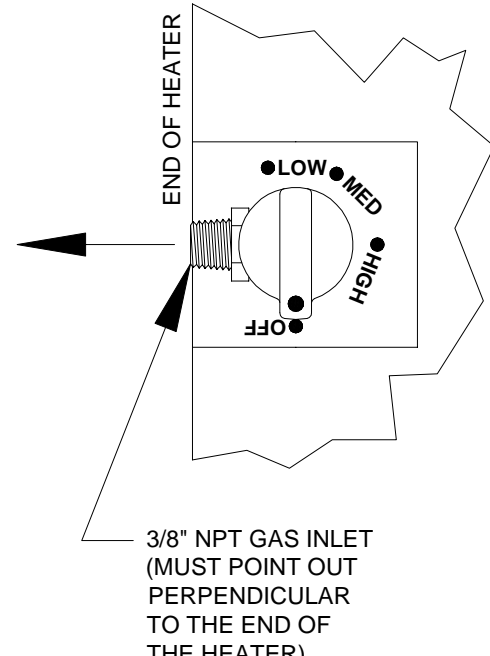
INSTALLATION INSTRUCTIONS	COMPONENTS IDENTIFICATION
<ol style="list-style-type: none"> <li>1. The 3-Position Manual Gas Control Shutoff Valve and Knob can be found in the heater carton.</li> <li>2. Remove the protective cap from the fitting on the heater.</li> <li>3. Use a small crescent wrench around the inlet fitting/valve assembly to tighten it to the fitting on the heater. See the WARNING in the Components Identification drawing.</li> <li>4. Turn inlet fitting/valve assembly clockwise a minimum of (3-1/2) three and one half turns before orienting the 3/8" NPT gas inlet as indicated in the drawings on this page.</li> <li>5. The 3/8" NPT gas inlet of the Manual Gas Control <b>MUST</b> be oriented to point out perpendicular from the end of the heater. Any deviation of the orientation from these instructions will affect the alignment of the gas control with the "OFF", "HIGH", "MED" and "LOW" markings on the heater control panel.</li> <li>6. The plastic knob slides onto the upright stem of the valve body. Align the red dot on the knob with the "OFF" position on the label.</li> </ol>	<p style="text-align: center;"><b>!! WARNING !!</b></p> <p>DO NOT USE WRENCH ON VALVE BODY. VALVE CAN BE DAMAGED.</p>  <p style="text-align: center;">3/8" NPT GAS INLET (MUST POINT OUT PERPENDICULAR TO THE END OF THE HEATER. FOR PROPER ALIGNMENT TO LABEL - SEE ORIENTATION BELOW)</p>
GAS CONTROL LOCATION	GAS CONTROL ORIENTATION
 <p style="text-align: center;"><b>TOP VIEW</b></p> <p style="text-align: center;"><b>SIDE VIEW</b></p>	<p style="text-align: center;">GAS CONTROL SHOWN IN "OFF" POSITION</p>  <p style="text-align: center;">3/8" NPT GAS INLET (MUST POINT OUT PERPENDICULAR TO THE END OF THE HEATER)</p>
<p><b>! WARNING !</b></p> <p>This 3-Position Manual Gas Control Shutoff Valve <b>MUST</b> be used with this heater. Any substitution of this control will void the CSA International design certification and all warranties. See Hazard Intensity Levels on page 2.</p>	

# ELECTRICAL SUPPLY AND THERMOSTATIC CONTROL

## ELECTRICAL SUPPLY

- Voltage: 120VAC – 60 Hz – 1 Phase applied to the factory supplied power cordset.
- Maximum Current: 0.6 Amp.
- Fused Control: 0.6 Amp. replaceable panel fuse.
- Flame Safety: Electronic.
- Ignition: Direct Spark.
- Wiring must conform to the latest edition of the National Electric Code (ANSI/NFPA 70) or local code legally authorized.
- Electrical power takeoff must be connected to a separately fused circuit with a disconnect or a circuit breaker, and must be properly polarized and grounded to the heater's power cord.
- Do not run wiring over the heaters or in direct view of radiant heat.
- If any of the wiring supplied must be replaced use type 16 AWG (1.0mm<sup>2</sup>), or equivalent with 2/64" (0.8mm) insulation and a minimum insulation temperature of 302°F (150°C).

## ! WARNING !

- ELECTRICAL GROUNDING INSTRUCTIONS. This heater is equipped with a three-prong (grounding) plug for your protection against shock hazard and should be plugged directly into a properly grounded three-prong receptacle. **DO NOT** cut or remove the grounding prong from this plug.
- Have a qualified electrician check that the circuit and wall receptacle is properly grounded and polarized.
- Wet/damp environments require a Ground Fault Interrupting (GFI) receptacle.
- Plug power cord directly into a GFI or properly grounded three-prong receptacle. **DO NOT USE EXTENSION CORDS OR ADAPTORS.**
- Clearance to combustibles must be maintained from all wiring and any electrical apparatus.

## CAUTION

- The Compact Tube Heater **MUST** be controlled by a thermostat, timer, or other automatically operated device with a relay contact closure (dry contacts).
- The terminal board on the heater is not a source of 24VAC. When wired to a 24VAC thermostat with dry contacts, the heater circuit is completed for thermostatic control. **THE HEATER WILL NOT OPERATE A 24VAC PROGRAMMABLE THERMOSTAT**, which requires it's own independent 24VAC supply.
- **DO NOT JUMPER THE THERMOSTAT TERMINALS AT THE TERMINAL BOARD ON TOP OF THE HEATER!** The heater will run continuously until the 120VAC power cordset is unplugged.
- **DO NOT REPLACE THE THERMOSTAT WITH A MANUAL ON/OFF SWITCH!** The heater is designed to work with a thermostat or timer. The heater will run continuously until the 120 VAC power cordset is unplugged or the switch turned off.
- **DO NOT SHORT THERMOSTAT WIRES TO HEATER BODY.** This will damage the controls internally.

## THERMOSTATIC CONTROL

- THERMOSTAT REQUIREMENTS: A simple 24-volt ON/OFF bimetallic thermostat should be used with this heater. Thermostat must have a relay contact closure (dry contacts) for the thermostat output. **DO NOT USE** a programmable type of thermostat unless it has isolated contacts that act as a relay for the heater's thermostat circuit and unless it has a separate and isolated power source to run the internal thermostat circuitry only.
- SPECIAL NOTE. If applicable, any hole in the plaster or panel through which the wires pass from the thermostat to the heater shall be sealed so as to prevent drafts from affecting the thermostat.

## THERMOSTAT INSTALLATION NOTES

- Locate the thermostat as specified in the heating plan.
- If it is not in the heating plan, follow the instructions provided with the thermostat.
- If instructions are not provided with the thermostat, locate it 4 to 5 feet (1.2-1.5m) above the floor where it will not be directly affected by the heat from the heater, outside drafts, or the sun.

## THERMOSTAT WIRING DIAGRAM

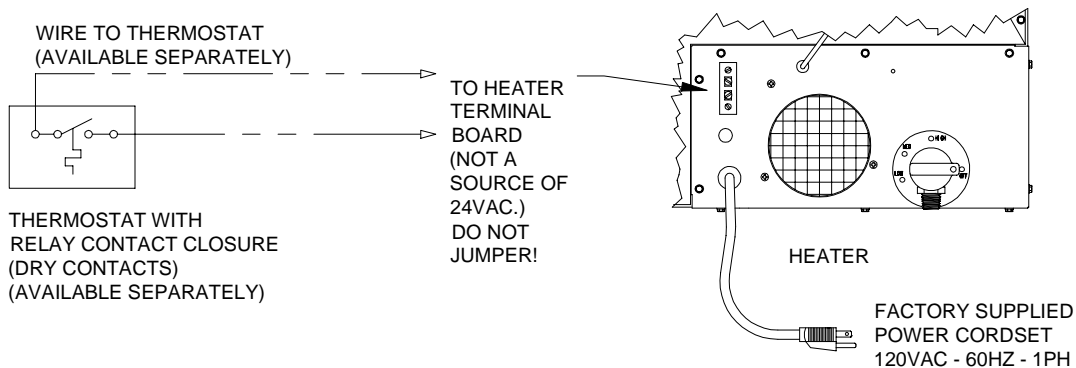

# GAS SUPPLY AND GAS PRESSURE

GAS SUPPLY	GAS PRESSURE
<ol style="list-style-type: none"> <li>1. Refer to the heaters' rating plate for type of gas (natural or LP/propane and operating pressure. The correct gas supply pressure is vital for the safe and efficient operation of this heater.</li> <li>2. All piping must be installed according to local codes. Use new clean pipe. Inspect and clean out any chips or debris before installing the pipe and fittings.</li> <li>3. A flexible connection between the supply line and the heater may only be used if permitted by local code.</li> <li>4. Always use two wrenches when mating pipe connections to the heater's gas control inlet. Excessive torque on the manifold may misalign the gas orifice.</li> </ol> <p><b>IMPORTANT:</b> The supply inlet piping must be perpendicular to the end of the heater. Any angled orientation of the gas control to one side or the other will misalign the gas control with the markings of "OFF", "HIGH", "MED" and "LOW" and may affect the ability of the heater to perform as designed.</p> <ol style="list-style-type: none"> <li>5. Install a 1/8" N.P.T. plugged tap, accessible for test gauge connection, immediately upstream of the gas supply connection to the heater. This is Test Point 'A' in the Gas Connection Diagram.</li> <li>6. A 6" (15cm) drip leg trap at the inlet connection is recommended.</li> <li>7. If a high pressure regulator is required, be sure it is installed in the gas line with the arrow indicating gas flow pointing in the proper direction.</li> <li>8. Piping joint compound must be resistant to the action of liquefied petroleum gases.</li> <li>9. Do not subject gas pressure regulators, flex connectors, and gas cocks on the heater to test pressure over 14" Water Column (W.C.) (36cm WC) while checking for piping leaks.</li> <li>10. All piping joints must be tested for leaks with a leak detecting soap solution.</li> </ol> <p><b>WARNING:</b> All components of a gas supply system must be leak tested prior to placing equipment into service. Never test for leaks with an open flame. See Hazard Intensity Levels, page 2.</p> <ol style="list-style-type: none"> <li>11. Purge all lines completely before attempting to ignite heater.</li> </ol> <p><b>WARNING:</b> Do not install any gas piping in heat zones.</p>	<p>The main supply line pressure must be limited to 10.5" W.C. (27cm WC) - natural gas and 13" W.C. (33cm WC) - LP/propane gas. If the line pressure can go above these limits at any time, a separate lockup service regulator must be used. The minimum supply line pressure at the inlet to the heater must, in no case, be lower than 7" W.C. (18cm WC) pressure for natural gas and 11" W.C. (28cm WC) pressure for LP/propane gas.</p> <p>Measure the supply inlet gas pressure at test point 'A' as shown in the Gas Connection Diagram. Ensure that the pressure is between the minimum and maximum noted in the Gas Pressure Requirements table. If the gas supply inlet pressure is above the maximum, CONSULT FACTORY.</p> <p>Use a water or red oil manometer when checking gas pressures. <b>DO NOT USE A DIAL GAUGE.</b> All measurements must be made when this and <b>ALL</b> other gas burning equipment are operating at maximum capacity. (Knob on unit must be set at "HIGH" when checking supply inlet gas pressure.)</p> <p>There is no adjustment for the heater's gas manifold pressure. The gas manifold pressure is factory set and is maintained by the heater's gas valve regulator when the supply inlet pressure is in the prescribed operating range.</p> <p>Natural gas models are orificed for 1000 BTU/cubic foot (37MJ/m<sup>3</sup>) of gas. Propane gas models are orificed for 2500 BTU/cubic foot (93MJ/m<sup>3</sup>) of gas.</p>
<b>GAS PRESSURE REQUIREMENTS</b>	
<b>TYPE OF GAS</b>	<b>SUPPLY INLET PRESSURE Water Column (W.C.)</b>
	<b>MINIMUM                      MAXIMUM</b>
<b>NATURAL</b>	<b>7"                                      10.5" (18cm)                                      (27cm)</b>
<b>PROPANE</b>	<b>11"                                      13" (28cm)                                      (33cm)</b>

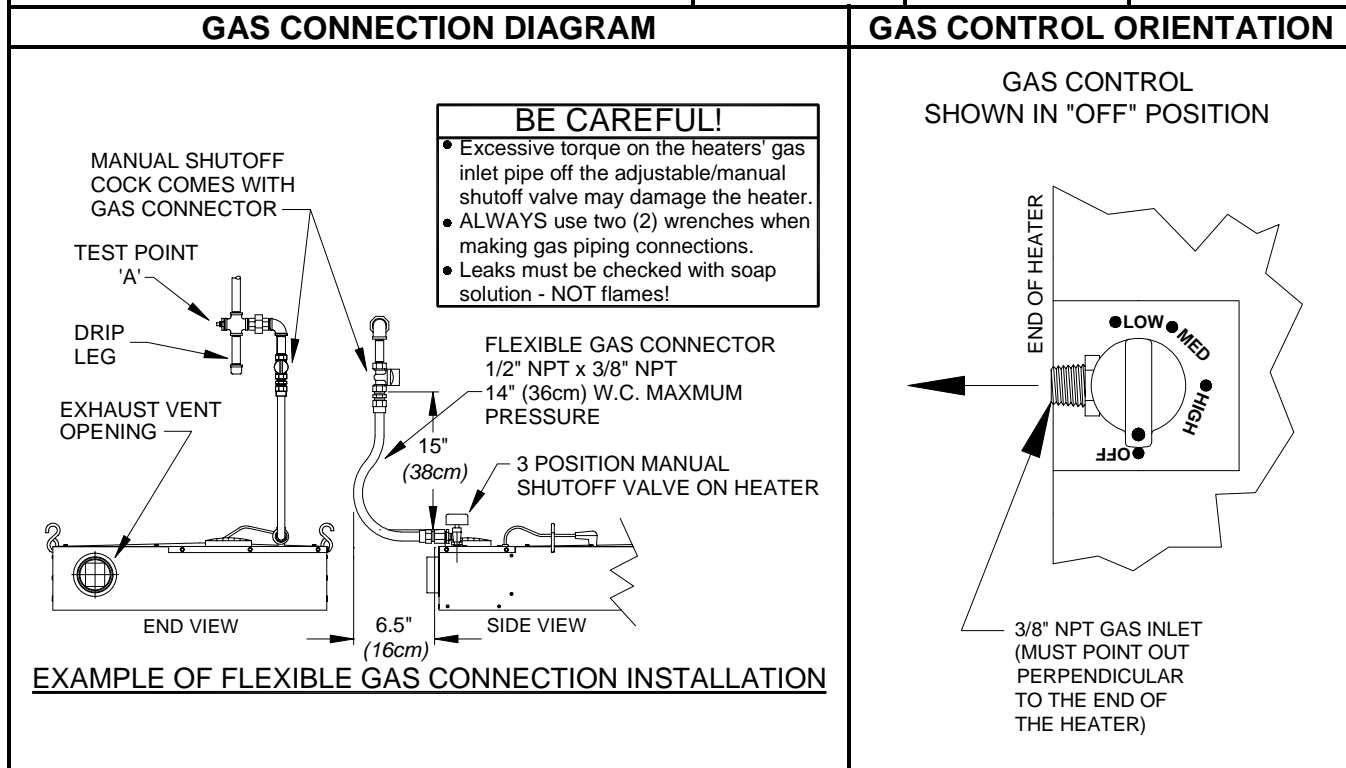

## STARTUP AND OPERATING INSTRUCTIONS

### STARTUP

#### INITIAL STARTUP AFTER INSTALLATION:

- Remove the 1/8" NPT pipe plug (shown as Test Point 'A' in the Gas Connection Diagram in the Gas Supply and Gas Pressure section) and connect the manometer. Turn the knob on the gas control valve to the "HIGH" position. (The gas inlet must have been oriented to point out perpendicular to the end of the heater.)
- Turn the electrical supply and set the thermostat to call for heat. The control system cannot determine the presence of flame unless it is grounded to the burner. It will lockout and shut off. Proper grounding and polarity are essential to its operation. If the heater does not work properly, refer to the Troubleshooting section.
- Check and, if necessary, adjust the incoming gas pressure to be within the required range of operation. Remove the manometer and replace the pipe plug. Check again for leaks. Cycle the heater several times by means of the thermostat, allowing at least (5) five minutes between cycles.
- If the heater is vented outdoors, observe and verify flue gases exiting from the exhaust vent are not impinging on the building construction. If it seems damage may occur, consult the factory.

### ! WARNING !

**WARNING: If you do not follow these instructions exactly, a fire or explosion may result causing property damage, personal injury, or loss of life.**

### FOR YOUR SAFETY READ BEFORE OPERATING

- This appliance does not have a pilot. It is equipped with an ignition device, which automatically lights the burner. **DO NOT** try to light the burner by hand.
- **BEFORE OPERATING**, smell all around the appliance area for gas. Be sure to smell next to the floor because some gas is heavier than air and will settle on the floor.  
WHAT TO DO IF YOU SMELL GAS:
  - Do not try to light any appliance.
  - Do not touch any electrical switches; do not use any phone in your building.
  - Immediately call your gas supplier from a neighbor's phone. Follow the gas supplier's instructions.
  - If you cannot reach your gas supplier, call the fire department.
- Use only your hand to push in or turn the gas control knob. Never use tools. If the knob will not push in or turn by hand, don't try to repair it, call a qualified service technician. Force or attempted repair may result in a fire or explosion.
- Do not use this appliance if any part has been under water. Immediately call a qualified service technician to inspect the appliance and to replace any part of the control system and any gas control that has been under water.

### OPERATING INSTRUCTIONS

1. STOP! Read the safety information above.
2. Set thermostat to lowest setting.
3. Turn off all electric power to the appliance.
4. This appliance is equipped with an ignition device, which automatically lights the burner. **DO NOT** try to light the burner by hand.
5. Push in and turn gas control knob clockwise to "OFF".
6. Wait (5) five minutes to clear out gas. If you smell gas, STOP! Follow the safety information above. If you do not smell gas, go to the next step.
7. Push in and turn gas control knob counterclockwise to "HIGH", "MED", "LOW". NOTE: Red dot on gas control knob must line up with desired position on label.
8. Turn on all electric power to the appliance.
9. Set thermostat to desired setting.
10. If the appliance will not operate, follow the instructions "To Turn Off Gas To Appliance" and call your service technician or gas supplier.

### TO TURN OFF GAS TO APPLIANCE

1. Set the thermostat to the lowest setting.
2. Turn off all electric power to the appliance if service is to be performed.
3. Push in and turn gas control knob clockwise to "OFF".

# OPERATION AND WIRING

## SEQUENCE OF OPERATION

- Thermostat sends the call for heat to the Ignition Detection Control (IDC) by closing the relay contact closure.
- IDC (35-715) applies 120VAC to run the fan motor.
- AFS-2 (normally open) airflow switch contacts close when it senses increased system pressure due to fan reaching operational speed. When these contacts close, the IDC begins a 30-second pre-purge time period.
- If AFS-1 (normally closed) airflow switch senses above normal system pressure, its contacts open. When these contacts open, the IDC prevents the gas valve from opening, or de-energizes the gas valve, and begins a 5-minute post-purge time period during which the fan continues run.
- At the completion of the pre-purge time, the IDC begins a 15-second trial for ignition time period and sends spark to the ignitor and applies 120VAC to open the gas valve.
- Burner ignites. DC electrical current flows from sensing electrode through flame to ground.
- IDC senses flame presence then turns off spark. Gas continues flowing through the valve.
- During the first trial-for-ignition period or upon any flame outage at the sensing electrode, the IDC responds and begins sending spark to the ignitor within 0.8 seconds. A 15-second trial-for-ignition time period begins to re-light the burner. If flame is reestablished, normal operation resumes. If the burner does not ignite after 15 seconds, the IDC de-energizes the gas valve and begins a 15-second inter-purge time period between trials to ignite the burner. If the burner fails to ignite after the third trial, the IDC will de-energize the gas valve and go into lockout mode.
- For lockout recovery, reset the thermostat below ambient temperature or disconnect the electrical power supply for 5 seconds.
- When the thermostat is satisfied, its relay contact closure opens, ending the call for heat signal to the IDC.
- The IDC de-energizes the gas valve, beginning a 5-minute post-purge time period during which the fan continues to run to protect the controls from an increase in temperature.
- At the completion of the post-purge time period, the IDC de-energizes the fan until there is another call for heat.

## HEATER WIRING LADDER DIAGRAM

If any of the original wire as supplied with the appliance must be replaced, it must be replaced with wiring material having a temperature rating of at least 302°F (150°C) and shall have a minimum size of 16 AWG.

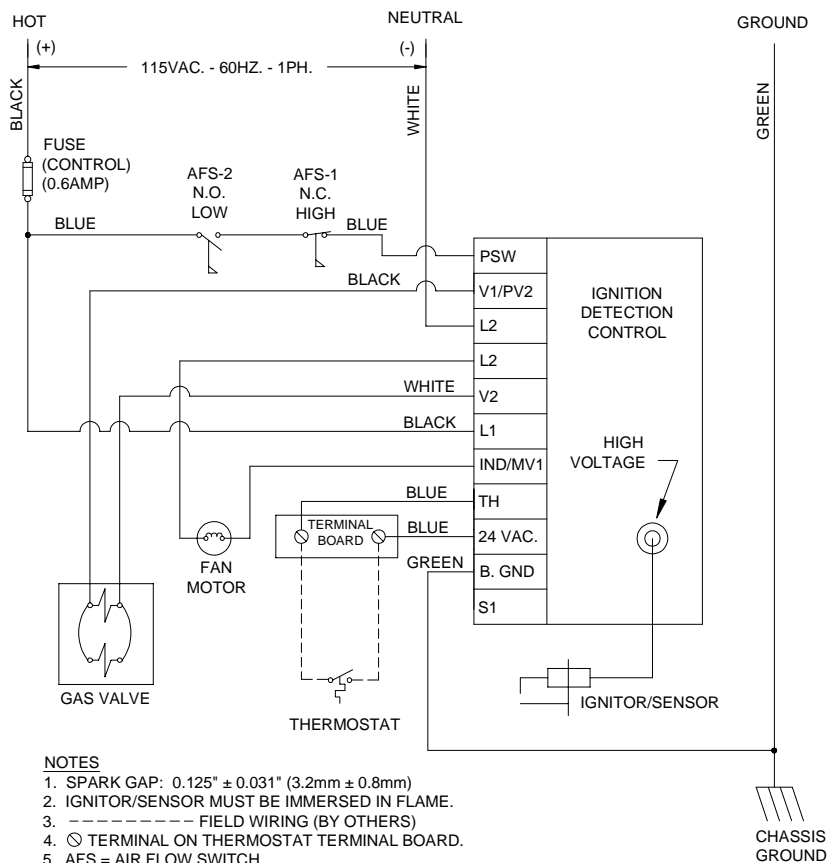

## HEATER WIRING INTERCONNECTION DIAGRAM

If any of the original wire as supplied with the appliance must be replaced, it must be replaced with wiring material having a temperature rating of at least 302°F (150°C) and shall have a minimum size of 16 AWG.

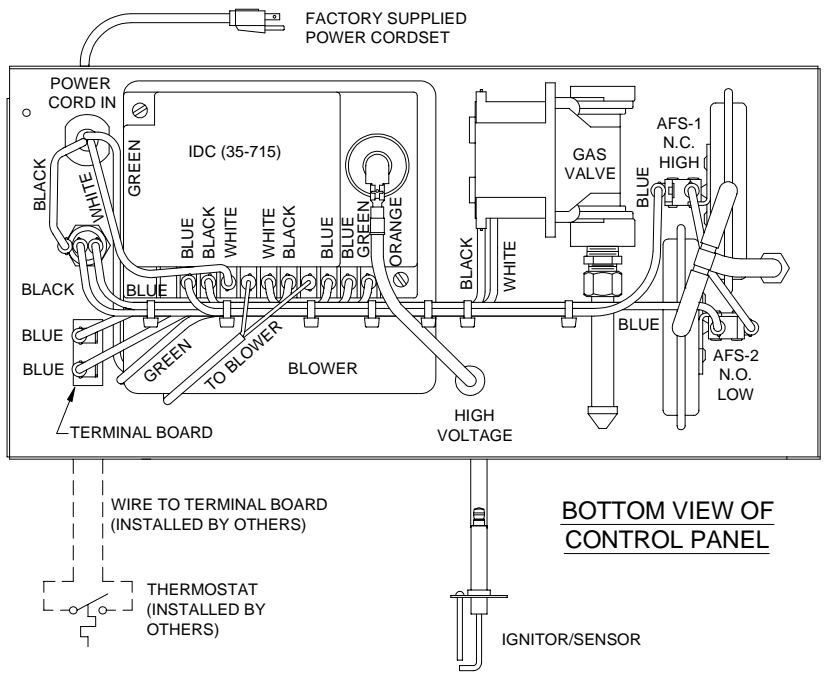

## MAINTENANCE

### ! WARNING !

An annual inspection and test, BEFORE the start of each heating season, performed by a qualified gas service agency, is recommended to verify the automatic gas ignition system, all associated gas and electrical components and the heater combustion chamber components operate according to the manufacturer's specifications. Components that are physically damaged, improperly replaced or otherwise fail to perform their function according to manufacturer's specifications **MUST BE** replaced immediately to avoid creating a fire, explosive and/or toxic hazards that can result in property damage, personal injury, or death.

### PREVENTATIVE MAINTENANCE

Annual maintenance done BEFORE the start of each heating season is all that is usually necessary. In dirty or dusty atmospheres, it may be necessary to check and perform needed maintenance more often as experience dictates. Maximum burner and heater efficiency can be maintained by keeping the heater as well as the inlet and exhaust ducting clean. During summer months, it is recommended to turn off the gas at the manual shutoff cock on the flexible gas connector going to the heater and to unplug the electrical power cordset.

1. FOR SAFETY REASONS, **BEFORE** PERFORMING ANY MAINTENANCE, UNPLUG THE HEATER FROM ITS ELECTRICAL POWER SUPPLY AND TURN OFF THE GAS AT THE MANUAL SHUTOFF COCK ON THE FLEXIBLE GAS CONNECTOR GOING TO THE HEATER!
2. Check the heated area and remove any combustible materials, gasoline, and other flammable vapors and liquids.
3. Check all suspension points from the ceiling, on the heater, combustion air ducts, and exhaust venting are secure. Chains are to be plumb and taut. All exhaust vent joints/connections **MUST BE** properly sealed (no flue gas leakage into the building).
4. Check combustion air ducting, inlet air cap, and air pressure sensing points for dust/dirt buildup or interior restrictions such as bird or insect nests. Clean, as necessary. Do the same for the exhaust venting.
5. Remove combustion air ducting coming from the top of the heater to check the condition of the blower wheel. Dirt and dust may be blown out with compressed air or a vacuum cleaner may be used. NOTE: The blower motor is prelubricated and does not require additional lubrication.
6. Visually inspect the ignitor/sensor assembly by removing it from its location on top of the heater. A single stainless steel screw fastens it to the heat exchanger tube. Remove any dirt, soot, or foreign objects from the electrode tips. Clean, then check the ceramic portion for chips or hairline cracks. If chips or cracks are found, replace ignitor/sensor. Set the spark gap to 0.125" +/- 0.031" (3.2mm +/- 0.8mm). Reinstall ignitor/sensor.
7. To examine the turbulator, remove the exhaust vent piping from the end of the heater. The turbulator is welded into the heat exchanger. Shine a flashlight into the tube. Brush the accessible portions of the turbulator and tube clean with a wire brush, if any scale or soot deposits are found. Examine the interior of the heater's tube with a flashlight for holes or cracks. Replace with a new heat exchanger tube assembly, if holes or cracks are found to prevent flue gas leakage into the building. Reattach exhaust vent piping. Make sure this joint is resealed to prevent flue gas leakage into the building.
8. To examine the burner, first disconnect the flexible gas hose connector from the Manual Control Shutoff Valve on the heater. Always use (2) two wrenches to prevent turning of the heater's piping or controls inside the control compartment. Next remove the heater's control panel. There are (10) ten screws to remove around the panel's perimeter. Lift control panel straight up and out. The burner core assembly is secured by (2) two screws. Remove the burner core assembly and check for dirt, etc. and clean as necessary. Check for chips or hairline cracks in the perforated ceramic disk at the end of the assembly. Replace with new burner core assembly, if necessary. Reattach the burner core assembly with two screws.
9. Examine the control panel components and wiring. If there are external signs of overheating or burn marks, replace the entire control panel. Check that all wiring connections are tight and secure. Inside the clear vinyl tube connected to the panel is a snubber (small aluminum cylinder) used in sensing airflow. Visually inspect for cleanliness. Refasten the control panel with the screws previously removed. **IMPORTANT:** This control panel **MUST SEAL** the compartment. A nuisance or unsafe operating condition can occur if not sealed. Do not leave any screw holes open.
10. To clean the reflector box, remove the large sheet metal panel on top of the heater. Be sure the ignitor/sensor assembly has been removed first. Pull the reflector box straight up and out. Clean the inside of the reflector box with mild soap and water and a clean cloth. Before reinstalling the reflector box, check the topside of the heater's serpentine heat exchanger tube for holes or cracks and if the clamp connection is tight. If problems are found, replace with new clamp or tube assembly. Reinstall reflector box and refasten the large sheet metal panel on top of the heater.
11. Verify the burner observation port is clean and free of holes or cracks. Clean or replace port, if necessary.
12. Outside surfaces of the heater may be cleaned with a damp cloth.
13. Reconnect flexible gas connector. Open the connector's manual shutoff cock and check for gas leaks with soap solution on all pipe joints disconnected during ANY maintenance procedures BEFORE putting heater back in service.
14. Any guards or other protective guards removed for servicing or maintenance of this heater must be replaced BEFORE trying to re-light the heater.
15. Plug the heater's electrical power cordset back into its receptacle. Using the thermostat, the heater should be cycled several times [allow (5) five minutes between cycles], to check its performance. The heater has a (5) five-minute post-purge. Visually observe the flame through the burner observation port. **THERE IS NO FIELD ADJUSTMENT OF THE BURNER FLAME POSSIBLE.** The flame should be blue with yellow tips. If the flame is excessively yellow, call a qualified gas service agency for service.
16. A qualified gas service agency must be contacted for service other than routine maintenance.

## TROUBLESHOOTING

SYMPTOM	POSSIBLE CAUSE	CORRECTIVE ACTION
Thermostat closes but nothing happens	1. No electrical power	1. Provide electrical power
	2. Fuse blown	2. Replace
	3. Thermostat defective	3. Replace
	4. Blower defective	4. Replace
	5. Wire(s) loose or disconnected	5. Repair
Thermostat closed: blower running: NO spark	1. Air flow sensing orifice blocked	1. Clear blockage of orifice in snubber
	2. Air flow switch lines plugged	2. Clean
	3. Exhaust vent or inlet air piping or cap restricted	3. Remove restriction
	4. Exhaust vent or inlet air piping is longer than allowed or diameter is too small	4. Rework to proper length, replace with proper diameter seal joints
	5. Control compartment not sealed/fastened down	5. Reseal [box press. 0.32-0.39"wc (8-10mm-wc)]
	6. Air flow switch (low) defective	6. Replace ONLY. DO NOT adjust
	7. Ignition wire disconnected	7. Reconnect (ensure power is off)
	8. Ignition wire defective	8. Replace
	9. Ignitor defective	9. Replace
	10. Ignition detection control (IDC) defective	10. Replace
Thermostat closed: blower running spark generated, burner fails to ignite	1. Gas supply closed	1. Open all incoming gas cocks/valves
	2. Ignitor defective	2. Replace
	3. Gas orifice dirty or restricted	3. Clean
	4. Gas valve fails to open when power applied	4. Replace gas valve
	5. Gas supply inlet pressure low	5. Provide required gas pressure
	6. Exhaust vent piping or cap restricted	6. Remove restriction
Ignition occurs, burner cycles off and will not recycle	1. No electrical ground	1. Connect to true earth ground
	2. Gas supply inlet pressure low	2. Provide required gas pressure
	3. Ignition detection control (IDC) defective	3. Replace
	4. Ignitor defective	4. Replace
	5. Exhaust vent piping or cap restricted	5. Remove restriction
Ignition occurs, burner cycles off and on.	1. Gas supply inlet pressure low	1. Provide required gas pressure
	2. Exhaust vent piping or cap restricted	2. Remove restriction
	3. Air flow switch(es) defective	3. Replace ONLY. DO NOT adjust
	4. Thermostat location inappropriate	4. Relocate thermostat
Burner "pops" during light-off (delayed ignition)	1. Exhaust venting or inlet air ducting improper	1. Correct the condition
	2. Burner core defective	2. Replace
	3. Building pressure negative	3. Provide combustion air from outdoors
	4. Ignitor defective	4. Replace
Heater efficiency reduced	1. Gas supply inlet pressure low	1. Provide required gas pressure
	2. Gas orifice dirty or restricted	2. Clean
	3. Foreign matter inside burner core	3. Clean
	4. Heater cycles on and off	4. Check previous symptom, relocate thermostat
	5. Blower assembly clogged	5. Clean as required
	6. Reflector dirty and reflectivity reduced	6. Clean with mild soap and water and soft cloth
Visual inspection of burner not possible	1. Sight glass (observation port) dirty or sooted	1. Clean sight glass
Radiant tubes leaking combustion gases	1. Tube connection loose	1. Replace
	2. Tube developing holes or cracks	2. Replace
	3. Exhaust vent piping or cap restricted	3. Remove restriction
Condensation	1. Exhaust vent length too long	1. Correct condition
	2. Exhaust vent piping gauge to light	2. Replace vent pipe minimum 26 gauge (0.4mm)
	3. Combustion air intake restricted	3. Remove restriction
	4. Lack of sufficient insulation	4. Correct
Tube corroding	1. Combustion air contaminated	1. Provide clean combustion air from outdoors
Exhaust stack sooting	1. Combustion air available is insufficient	1. Provide (1) one square inch of free air per 1000 BTUH input (22cm <sup>2</sup> /kW)
	2. Gas improper	2. Correct
	3. Exhaust vent length too long	3. Correct
	4. Combustion air piping length/diameter improper	4. Correct
	5. Blower dirty	5. Clean
	6. Blower weak	6. Replace
	7. Control compartment not sealed/fastened down	7. Reseal [box press. 0.32-0.39"wc (8-10mm-wc)]

## REPLACEMENT PARTS

### ! WARNING !

**Any substitutions of factory approved parts without prior written permission may result in unsafe operation, property damage, personal injury, death, voids CSA design certification, and all warranties.**

### PARTS LIST

PART NAME	PART NUMBER
Control panel (natural gas)	20076
Control panel (propane gas)	20077
3-Position manual gas control shutoff valve (natural gas)	00057
3-Position manual gas control shutoff valve (propane gas)	00057P
Knob for manual gas control	00079
Burner core	10007
Ignitor/sensor	00045
High voltage ignition wire	10010

**Due to continuous product improvement, please provide serial and model number prior to ordering replacement parts to assure safe repairs and maintenance.**

**Internal manufacturing and testing requirements prohibit offering individual control panel components for field installation. Contact the factory service department with the model number and serial number to ask specific service questions.**

### GAS CONVERSION

It is feasible to convert the type of gas used by the heater from natural gas to LP/propane gas or from LP/propane gas to natural gas. Identify the model number and serial number of the heater as shown on the serial rating plate on the heater.

Internal manufacturing and testing requirements prohibit offering individual control panel components for field installation. Contact the factory service department with the model number and serial number to arrange for a gas conversion.

THIS PAGE INTENTIONALLY LEFT BLANK

**FOR SERVICE OR REPAIR, FOLLOW THESE STEPS IN ORDER:**

**FIRST:** Contact the Installer

Name \_\_\_\_\_

Address \_\_\_\_\_

\_\_\_\_\_

\_\_\_\_\_

Phone \_\_\_\_\_

**SECOND:** Contact the Nearest Distributor

Model No.: \_\_\_\_\_

Unit Serial No.: \_\_\_\_\_

Date of Installation: \_\_\_\_\_

**Solaronics, Inc.**  
**GAS INFRA-RED HEATERS**



P.O. Box 80217, Rochester MI 48308-0217  
Toll Free: 1-800-223-5335  
Phone: (248) 651-5333  
FAX: (248) 651-0357  
E-mail: [sales@solaronicsusa.com](mailto:sales@solaronicsusa.com)

View our product lines on our websites.  
SOLARONICS, INC: [www.solaronicsusa.com](http://www.solaronicsusa.com)  
Thomas Register: [www.thomasnet.com](http://www.thomasnet.com)  
Sweet's Directory: [www.sweets.com](http://www.sweets.com)