

## GAS INFRA-RED HEATERS

# Residential Garage Heater

## Installation, Operation, & Maintenance Instruction Manual

*(Mount a copy of these instructions adjacent to the heater)*

### MODEL IDENTIFICATION

Record the information from the product identification label here for future reference.

Heater Model No.: \_\_\_\_\_ Heater Serial No.: \_\_\_\_\_

Rating: \_\_\_\_\_ BTUH Type of Gas: Nat \_\_\_ LP/Propane \_\_\_ Date Installed \_\_\_\_\_

### FOR YOUR SAFETY

#### IF YOU SMELL GAS:

1. Extinguish any open **FLAME**.
2. Do **NOT** try to light any appliance.
3. **OPEN** windows.
4. Do **NOT** touch electrical switches; do **NOT** use any telephone in the house.
5. **CALL** your gas supplier immediately from a **NEIGHBOR'S** home. Follow the gas supplier's instructions.
6. **IF** you can't reach your gas supplier, **CALL** the **FIRE DEPARTMENT**.

### FOR YOUR SAFETY

Do not store or use **GASOLINE** or other **FLAMMABLE VAPORS** or **LIQUIDS** in the vicinity of this or any other appliance.

**This unit is not to be installed in indoor living/sleeping areas.**

### !! WARNING !!

THESE INSTRUCTIONS must be carefully read and completely understood **BEFORE** attempting to install, operate, or perform maintenance service on this **GAS-FIRED APPLIANCE**. Installation and Service **MUST** be performed by a **QUALIFIED** service agency, installer, contractor, or gas supplier. Failure to comply with the manufacturer's instructions can result in unsafe operation, property damage, personal injury, and/or death. A gas-fired appliance can expose you to substances in fuel or from fuel combustion which have been determined by the State of California to cause cancer, birth defects, or other reproductive harm. Contact factory for further information. Keep these instructions for future reference.

### EXPLANATION OF HAZARD INTENSITY LEVELS

**DANGER:** Failure to comply **WILL** result in severe personal injury, death, and/or property damage.  
**WARNING:** Failure to comply could result in severe personal injury, death, and/or property damage.  
**CAUTION:** Failure to comply could result in minor personal injury, and/or property damage.

**This manual is to be left with the owner after installation of this unit.**

**OWNER:** Store this manual in a safe place to furnish your serviceman with the necessary information for servicing.

QUESTIONS? Call the factory: Monday – Friday 8 a.m. to 5 p.m. Eastern Time

## WARNINGS

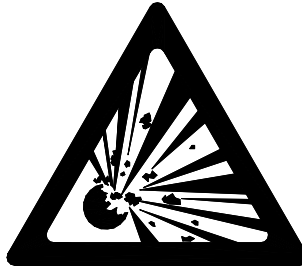
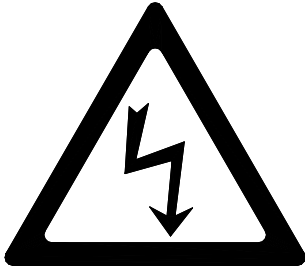

- Protect yourself and others by observing all safety information.

### WARNING

#### FIRE OR EXPLOSION HAZARD

*Can cause property damage, severe injury or death.*

- Read manual carefully before installing, or servicing this equipment, or serious injury or death may result.
- Check minimum clearance to combustibles to make certain that heater is in a safe location. Combustible items located too close to the heater could cause a **serious fire hazard**. In storage areas, signs for maximum permissible stacking height to maintain clearance from the heater to combustible materials must be posted adjacent to the heater thermostats or in the absence of such thermostats in a conspicuous location.
- Operating the heater in an atmosphere containing combustible dust or flammable vapors is dangerous and may potentially result in injury or death.
- Heaters must be oriented in such a way as to maintain minimum clearances to vehicles parked underneath them.
- This heater expands and contracts with each cycle. The installation of the gas connection and mounting hardware must accommodate this movement; otherwise, a fire or explosion hazard may occur.
- This heater is equipped with an automatic ignition and does not contain a pilot. **DO NOT** attempt to light the burner manually, this could result in serious personal injury or fire hazard.

### CAUTION

#### MECHANICAL HAZARD

- **DO NOT** use high pressure to test the gas pipes with the burner still attached. This will cause damage to the controls within the burner requiring them to be replaced.
- If heater is being operated in an atmosphere with a negative pressure or an atmosphere containing contaminants, an outside combustion air supply is required. Failure to provide outside combustion air may allow excessive heat to back up to the blower wheel and bearings severely shortening service life.
- Correct inlet pressure is important to efficiency and long lasting operation of the burner.
- The burner, tubing, and accessories expand and contract with each cycle. The system must be installed so that the mounting hardware and gas line will accommodate these changes.
- All models of these tube heaters include a turbulator, which **must** be located inside the **last** 10-foot (3.0 m) tube [Note: 15-foot (4.6 m) models have the 10-foot (3.0 m) tube with turbulator before the 5-foot (1.5 m) tube.]
- Before servicing the burner or removing the cover panel, all electrical and gas supplies must be disconnected.
- Give consideration to construction such as partitions, storage racks, hoists, etc., and their relation to the installation of the heater.
- The heater must be installed and serviced **ONLY** by trained and qualified gas installation and service personnel.

## IMPORTANT

**Failure to follow these instructions may result in property damage, injury or death.**

**These Residential Garage Heaters shall not be used in the following environments:**

- |   |  |
|---|--|
| <ul style="list-style-type: none"> <li>• <u>Indoor living/sleeping quarters</u></li> <li>• Enclosed swimming pools</li> <li>• Outdoors</li> </ul> | <ul style="list-style-type: none"> <li>• Explosion-proof environments</li> <li>• Process heating</li> <li>• Contaminated atmosphere applications.</li> </ul> |
|---|--|

**NOTE: Contact factory if in any doubt.**

## TABLE OF CONTENTS

<ul style="list-style-type: none"> <li>This instruction manual may not cover all details or variations in this equipment, or cover every possible situation to be met in connection with installation, operation, or maintenance. Should problems arise that are not covered sufficiently in these instructions, the purchaser is advised to contact the factory's engineering department for further information.</li> </ul>	
<b>SECTION TITLES</b> – summary of information included	<b>PAGE(S)</b>
<b>WARNINGS</b> – precautions and important safety information	2
<b>TABLE OF CONTENTS</b>	3
<b>INSTALLATION CODES</b> – applicable codes and warnings	4-5
<b>CLEARANCE TO COMBUSTIBLES</b> – minimum distances from heater to combustible materials	6
<b>MOUNTING CONSIDERATIONS</b> – minimum heater mounting heights, high altitude considerations	7
<b>OVERVIEW DRAWINGS</b> – overview of combustion air supply, exhaust venting and installation	8-9
<b>COMBUSTION AIR SUPPLY</b> – outdoor air supply, maximum length of air supply pipe, air supply cap specifications and indoor air supply	10
<b>EXHAUST VENTING</b> – outdoor exhaust venting, maximum length of exhaust vent pipe, vent cap specifications	11
<b>ELECTRICAL SUPPLY AND THERMOSTATIC CONTROL</b> – electrical ratings, schematics, 24 and 120 VAC thermostat arrangements, illustrations	12
<b>OPERATION AND SHUTDOWN</b> – sequence of operation, shutdown, burner wiring diagrams	13
<b>GAS SUPPLY AND GAS PRESSURE</b> – gas piping, inlet pressure and manifold pressure	14
<b>STARTUP</b> – procedures, burner diagram and ignitor diagram	15
<b>MAINTENANCE</b> – procedures with safety precautions	16
<b>TROUBLESHOOTING</b> – symptoms, possible causes and corrective actions	17
<b>REPLACEMENT PARTS</b> – exploded view of burner and part descriptions	19
<b>U-TUBE INSTALLATION</b> – horizontal or angled mounting of U-tube heaters	20
<b>U-BEND REFLECTOR INSTALLATION</b> – exploded view and instructions	21
<b>BASIC SYSTEM CONFIGURATIONS</b> – straight and U-tube configurations with component identification	22
<b>COMBUSTION CHAMBERS/HEAT EXCHANGERS</b> – components and specifications	23
<b>INSTALLATION</b> – preparation and installation	24-25
<b>PRESS-FIT TUBE ASSEMBLY TIPS</b> – helpful tips to assemble press-fit tubes	26-27

## INSTALLATION CODES (1 OF 2)

### !! WARNING: READ THIS FIRST !!

Initial adjustment and light-off **MUST** be performed by qualified, trained, and experienced personnel familiar with combustion systems, electrical and gas control/safety circuitry, and overall installation. Instructions provided by the company or individual responsible for the complete installation of the entire system take precedence over those provided by this instruction manual. If these instructions conflict with local codes or regulations, contact the factory at the on the cover **BEFORE** start-up. The installer **MUST** be familiar with all of the various requirements and is responsible for compliance with applicable codes.

#### AGENCY DESIGN CERTIFICATION:

CSA International (formerly A.G.A. and CGA).

- United States: A.G.A. Requirement No. 7-89
- Canada: CSA 2.32a-M99

#### GENERAL INSTALLATION & GAS CODES:

Heater must be installed **ONLY** for use with type of gas appearing on its rating plate.

- United States: In the absence of local codes, installation must comply with the National Fuel Gas Code ANSI Z223.1 (NFPA-54) - latest edition.
- Canada: In the absence of local codes, installation must comply with CAN/CGA B149.1 and B149.2 Installation Codes in Canada-latest edition.

#### GAS SUPPLY LINES:

A 1/8 inch NPT plugged tap must be installed in the gas line connection immediately upstream of the burner farthest from the gas supply meter to check and confirm the system's gas pressure.

- United States: Installation must comply with the National Fuel Gas Code ANSI Z223.1 (NFPA-54)-latest edition.
- Canada: Installation must comply with CAN/CGA B149.1 AND B149.2 Installation Codes in Canada-latest edition.

**INSTALLATION CODES (2 OF 2)****!! WARNING: READ THIS FIRST !!****MANUAL GAS SHUT-OFF (CANADA ONLY):**

A manual shut-off valve shall be of the plug, ball, or eccentric type and it shall not be subjected to either a temperature or pressure greater than its certified rating. A readily accessible manual shut-off valve shall be installed to control the supply of gas to each heater and the valve shall be located, in either the drop or riser, as close as possible to the valve train of a commercial or industrial type appliance.

**ELECTRICAL:**

All electric work, particularly grounding, must conform with all local requirements and:

- United States: National Electric Code ANSI/NFPA 70-latest edition
- Canada: Canadian Electric Code CSA C22.1 – latest edition.

**VENTING:**

Refer to the following standards for proper location, sizing, and installation of vents as well as information on clearance requirements when passing through walls for venting purposes:

- United States: National Fuel Gas Code ANSI Z223.1 (NFPA-54)-latest edition.
- Canada: CAN/CGA B149.1 and B149.2 Installation Codes in Canada – latest edition.

## CLEARANCE TO COMBUSTIBLES

<b><u>!! WARNING !!</u></b>	<b><u>!! WARNING !!</u></b>	<b><u>!! WARNING !!</u></b>
<p>The minimum clearances as shown in the diagram below <b><u>MUST</u></b> be maintained from vehicles parked below this heater. The radiant heat can damage painted surfaces.</p>	<p>Failure to comply with these clearances could result in fire, property damage, personal injury, and/or death. Supervise young children when in the same room as the heater.</p>	<p>The area in all directions surrounding the heater <b><u>MUST</u></b> be kept clear from combustible materials, and other flammable vapors and liquids.</p>

1	<p>Minimum clearance specified below <b><u>MUST BE</u></b> maintained to combustible materials and any other material that may be damaged by temperatures of 90°F above (50°C above) ambient room temperature. The specified distance <b><u>MUST BE</u></b> maintained from the top surface of carpeting, tile, etc.</p>
2	<p>Minimum clearance to combustibles are also specified on each heater’s serial plate located next to the blower on the burner.</p>
3	<p>According to the National Fuel Gas Code, section 10.18.2(3), “In locations used for storage of combustible materials, signs shall be posted to specify the maximum permissible stacking height to maintain required clearances from the heater to combustibles.”</p>
4	<p><b><i>CHILDREN AND ADULTS SHOULD BE ALERTED TO THE HAZARDS OF HIGH SURFACE TEMPERATURES ON THE HEATER, AND SHOULD STAY AWAY TO AVOID BURNS OR CLOTHING IGNITION.</i></b></p>
5	<p><b><i>CLOTHING OR OTHER FLAMMABLE MATERIALS SHOULD NEVER BE HUNG FROM THE HEATER, OR PLACED ON OR NEAR THE HEATER. CERTAIN MATERIALS OR ITEMS, WHEN STORED UNDER THE HEATER, WILL BE SUBJECTED TO RADIANT HEAT AND COULD BE SERIOUSLY DAMAGED.</i></b></p>

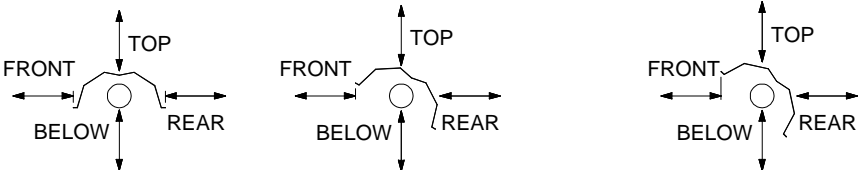
<p style="text-align: center;"><b>CLEARANCES APPLICABLE FOR ALL HEATERS</b> Inches (Centimeters)</p> <p style="text-align: center;"><b><u>TOP OF REFLECTOR</u></b> 12 (31)</p> <p style="text-align: center;"><b><u>END OF BURNER</u></b> 12 (31)</p> <p style="text-align: center;"><b><u>END OF U-BEND</u></b> 50 (127)</p>		<p><u>0° MOUNTING</u>                      <u>1° – 30° MOUNTING</u>                      <u>31° – 45° MOUNTING</u></p>					
							
		<ul style="list-style-type: none"> <li>Reflector width = 15.75” (40 cm)</li> <li>Top, Front, and Rear clearances are measured from reflector.</li> <li>Below clearance is measured from bottom of tube.</li> <li>Clearance to combustibles measurements are given in inches and (centimeters).</li> </ul>					
		<b>0° to 30° Reflector Angle</b>			<b>31° to 45° Reflector Angle</b>		
<b>MBTUH</b>	<b>(kW)</b>	<b>FRONT</b>	<b>REAR</b>	<b>BELOW</b>	<b>FRONT</b>	<b>REAR</b>	<b>BELOW</b>
40	(11.7)						
45	(13.2)	40 (102)	40 (102)	40 (102)	40 (102)	12 (31)	40 (102)
50	(14.6)						
55	(16.1)						
60	(17.6)	50 (127)	50 (127)	50 (127)	50 (127)	12 (31)	50 (127)
<p><b>MINIMUM MOUNTING HEIGHT:</b> Bottom of tube to floor: 8 ft. (2.4 m) U.S.A., 7 ft. (2.1 m) Canada</p>							

## MOUNTING CONSIDERATIONS

- Clearance to combustibles must be observed at all times.
- In all cases, minimum installation height: 8 ft. (240 cm) U.S.A., 7 ft. (214 cm) Canada, from floor ground level.
- The heater must be controlled by a thermostat, timer, or other automatically operated device. On/off switches or direct wiring to a circuit breaker are not allowed.
- Verify the buildings overhead structure has sufficient strength and proper suspension means to support the weight of the heater
- Observe and verify all chains are plumb and vertical. A chain that is not plumb and vertical may cause damage to the heater.
- To maximize the heater's effectiveness to cover the space to be heated, it is recommended the heater be hung as high as possible and along an uncluttered wall to give the heater's reflector the widest possible "view".
- Leave enough space around the burner box to permit future servicing.
- Choose a location allowing easy installation of the vent piping system.
- Each suspension point must be capable of supporting a minimum of 150 lbs. (65 kg).
- Allow for heater's movement during expansion and contraction through the operation cycle.
- Heaters shall not be installed in living/sleeping areas.
- U-tube heaters must have a reflector installed over the U-bend tube.

### **CAUTION: HIGH ELEVATION**

- If a heater is to be installed at a high elevation, in excess of 2000 feet (610 m) above sea level, the installer is advised to verify it has been properly factory modified for this application in accordance with the National Fuel Gas Code.

# OVERVIEW DRAWINGS (1 OF 2)

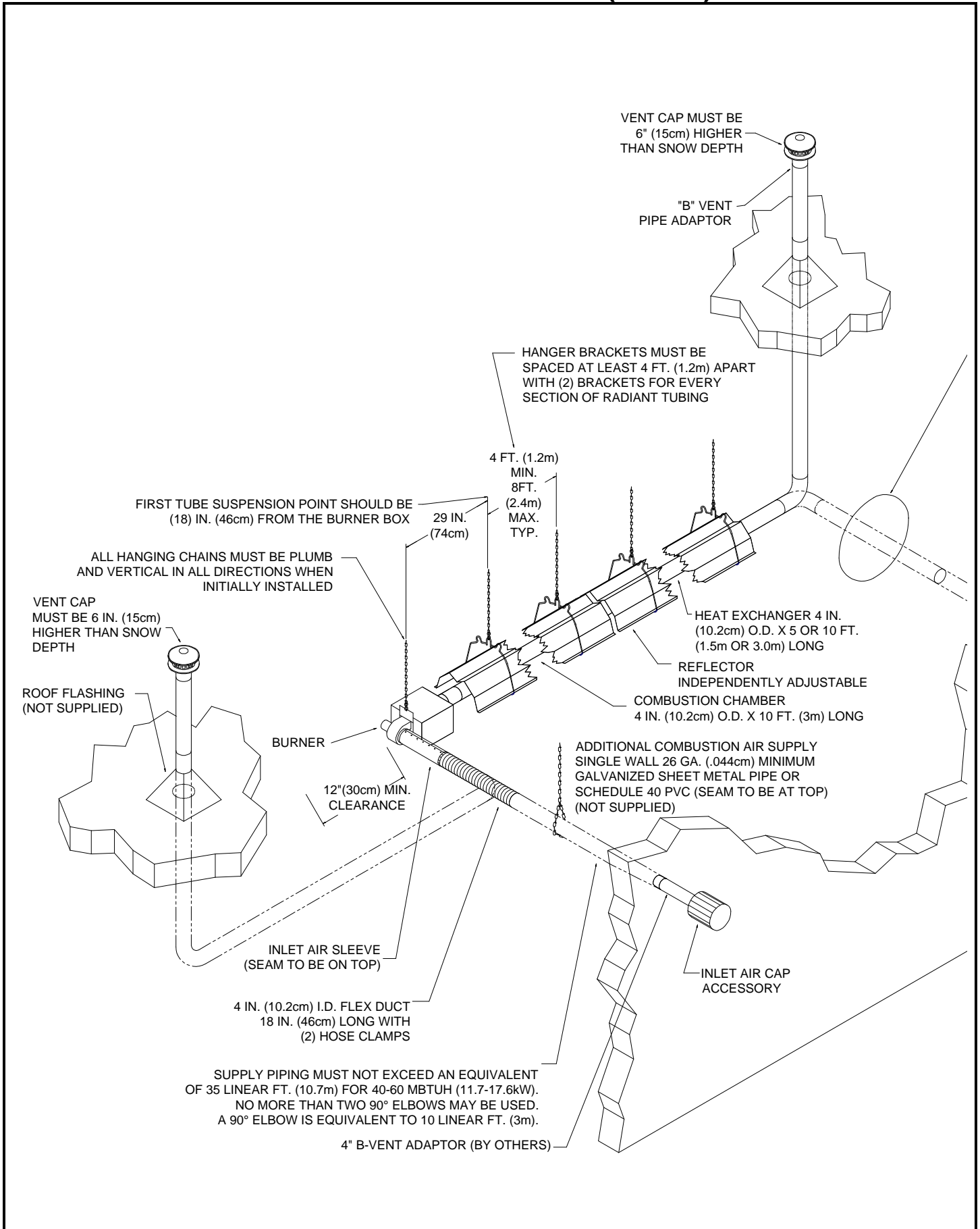

# OVERVIEW DRAWINGS (2 OF 2)

MAINTAIN 18 IN. (46cm) MINIMUM CLEARANCE TO COMBUSTIBLES FOR ENTIRE LENGTH OF PIPING

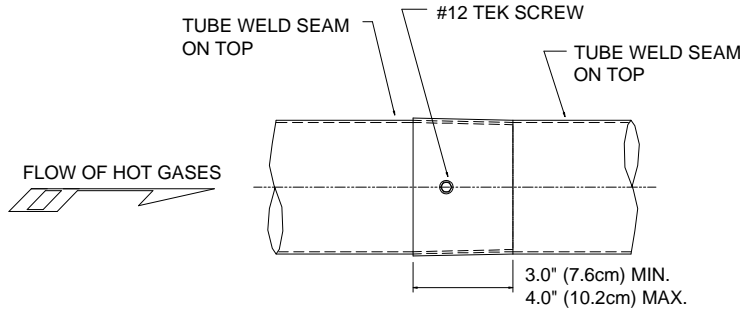

**HEAT EXCHANGER MOUNTING ARRANGEMENT**

ADDITIONAL EXHAUST VENT PIPING 4" (10.2cm) I.D. SINGLE WALL 26 GA. (.044cm) MINIMUM GALVANIZED SHEET METAL (OR OTHER FACTORY-APPROVED MATERIALS) (SEAM TO BE ON TOP) (NOT SUPPLIED) MUST NOT EXCEED AN EQUIVALENT OF 35 LINEAR FT. (10.7m) FOR 40-60 MBTUH (11.7-17.6kW). NO MORE THAN 2 ELBOWS MAY BE USED. A 90° ELBOW IS EQUIVALENT TO 10 LINEAR FT. (3m). A 45° ELBOW IS EQUIVALENT TO 5 LINEAR FT. (1.5m).

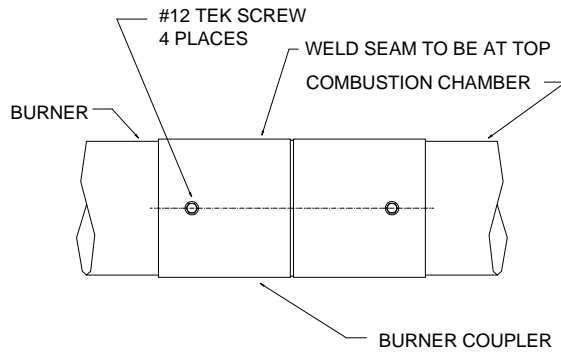

**BURNER COUPLER MOUNTING ARRANGEMENT**

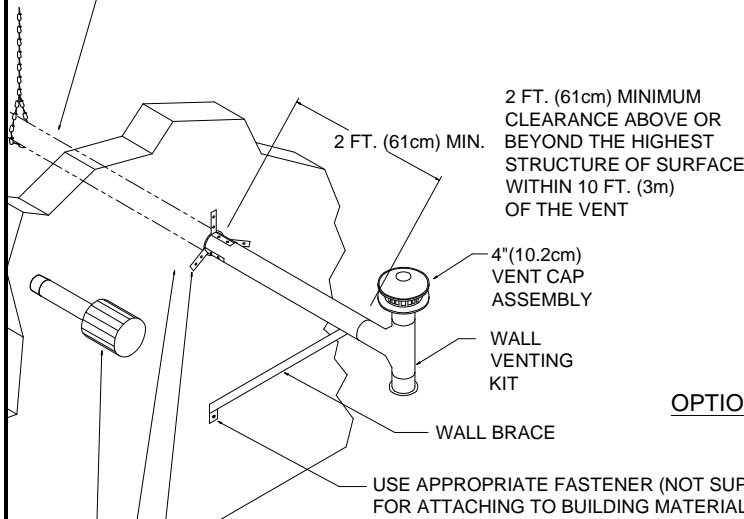

2 FT. (61cm) MINIMUM CLEARANCE ABOVE OR BEYOND THE HIGHEST STRUCTURE OF SURFACE WITHIN 10 FT. (3m) OF THE VENT

4" (10.2cm) VENT CAP ASSEMBLY  
WALL VENTING KIT  
WALL BRACE

USE APPROPRIATE FASTENER (NOT SUPPLIED) FOR ATTACHING TO BUILDING MATERIAL

FOR ALL INDOOR VENT JOINTS: USE RTV SEALANT TO PREVENT HOT FLUE GAS LEAKAGE INTO THE BUILDING (USE A SHEET METAL PIPE AND CRIMPER FOR JOINING IDENTICAL SIZE SHEET METAL PIPES), USE THREE (3) #6 SHEET METAL SCREWS (SMS) PER VENT PIPE JOINT. THE VENT PIPE SEAM SHOULD BE ON TOP WITH ONE SMS ON TOP AND ONE SMS 120 DEGREES FROM THE TOP ON EACH SIDE.

(3) 90 DEGREE BRACES EQUALLY SPACED

FOR COMBUSTIBLE WALLS ONLY USE A 2" (5.1cm) CLEARANCE NON-COMBUSTIBLE VENTILATING METAL THIMBLE (NOT SUPPLIED). FOR NON-COMBUSTIBLE WALLS ONLY 4.25" (10.8cm) DIA. HOLE FOR 4" (10.2cm) O.D. PIPE ADD NON-COMBUSTIBLE PROTECTION AROUND THE HOLE IF NECESSARY.

4" (10.2cm) WALL VENT CAP ALTERNATE ACCESSORY

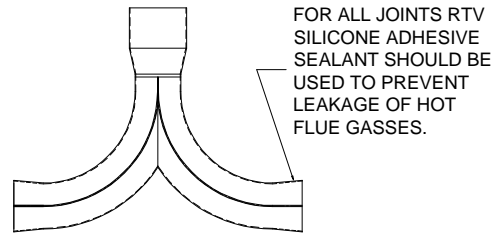

**4" x 4" x 5" Y-COUPLER (10 x 10 x 13cm) (OPTIONAL ACCESSORY)**

**OPTIONAL COMMON VENTING THROUGH ROOF OR WALL**  
BOTH HEATERS MUST BE CONTROLLED BY A SINGLE THERMOSTAT

**NOTE**

This drawing is for general reference only! It shows only general design guidelines and it does not provide construction details.

**CAUTION**

- A U-Tube heater may have a 180 degree U-bend interposed AFTER the first ten (10) feet (3.0 m).
- Electrical wiring diagrams can be found in the ELECTRICAL SUPPLY AND THERMOSTATIC CONTROL section.
- The heater must be controlled by a thermostat, timer or other automatically operated device.

# COMBUSTION AIR SUPPLY

## WARNING

This heater is **NOT** an explosion-proof heater. Where the possibility of exposure to volatile or low flash point material exists, it could result in severe personal injury, death, and/or property damage. Consult your local fire marshal or insurance agency to determine the classification of the building to be heated.

- Atmospheric air for combustion may come from either outdoors or indoors (within the building).
- Installation of combustion air supply must comply with the instructions, drawings, and installation notes provided in this section.

### OUTDOORS

- In buildings contaminated with excessive dust or dirt, containing substances which when combined with flame and exhaust products result in corrosive gases, or those under a negative pressure, combustion air must be taken from outdoors.
- Outdoor air supply may be accomplished by bringing air inside through piping from either the roof or wall as shown below.
- The inlet air roof venting cap (roof) or inlet air box (wall) must be located at least (3) three feet (1m) away from any vent termination and in a manner preventing blockage by snow.
- Components used to bring in outdoor air, when supplied by others, must be identical to those specified in this manual and be Metalbestos brand or equal. **NO SUBSTITUTIONS.**
- Single wall 4" (10.2cm) I.D. galvanized pipe of 20 gauge (.035" or 0.9mm) or schedule 40 PVC is recommended for combustion air supply piping.
- For all systems, total linear (straight) pipe run must not exceed (35) thirty-five feet (11m) within the building.
- A 90-degree elbow is equivalent to (10) ten linear feet (3m).
- No more than (2) two 90-degree elbows are permitted.
- It may be necessary to insulate the inlet air supply piping to eliminate condensation from warm inside air on the piping.
- In very extreme cases, for protection against any exterior contaminants, a blower enclosure may be installed. The outdoor air supply piping is then attached to the enclosure.

### INDOORS

- When combustion air is to be taken from inside a tightly sealed or closed building, an opening must be installed to supply the burner with sufficient air for combustion.
- The opening must be made so that for every 1,000 BTUH (293W) of the total input of all gas-fired equipment, one square inch (6.5cm<sup>2</sup>) or more of free area opening is provided.
- If combustion air is supplied from the space to be heated, it must be free of contaminants that may interfere with the proper and safe operation of the heater. Some contaminants like halogenated hydrocarbons or other corrosive elements may shorten the life of the heater.

### IMPORTANT

- **DO NOT** use collapsible material such as dryer duct as a substitute for single wall galvanized or PVC pipe. It will restrict air flow to the burner causing improper operation.
- Inlet air piping must be well supported since additional stress may be encountered due to expansion during heater operation.
- Outdoor air must be free of contaminants.
- A minimum of (3) three feet (1m) is required between the inlet air roof venting cap and the nearest vertical vent terminal on a roof.
- If the inlet air roof venting cap is within (10) ten feet (3m) of a vertical vent terminal on a roof, the vertical vent terminal must be at least (12) twelve inches (30.5cm) higher than the inlet air roof venting cap.

### THRU-THE-WALL

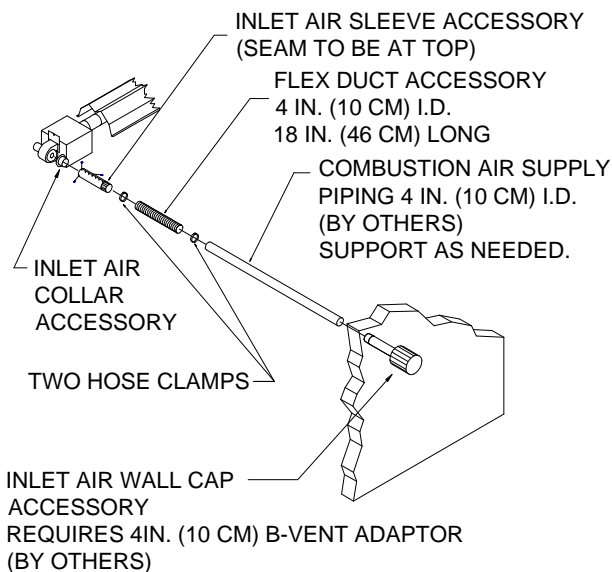

### THRU-THE-ROOF

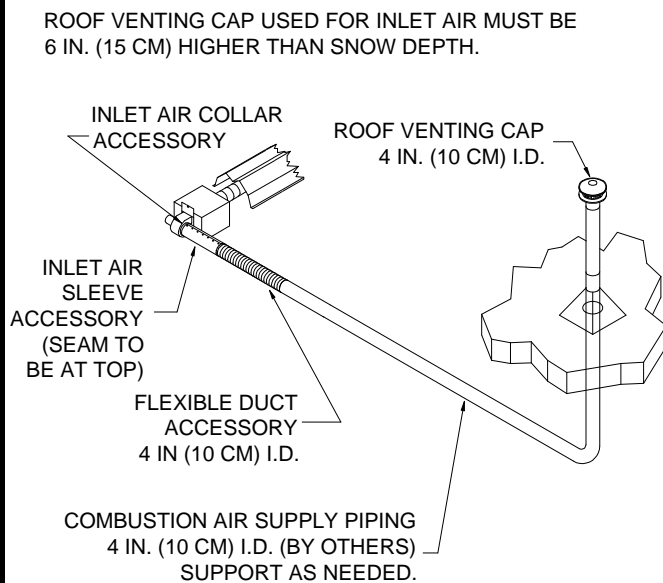

# EXHAUST VENTING

## WARNING

This heater is **NOT** an explosion-proof heater. Where the possibility of exposure to volatile or low flash point material exists, it could result in severe personal injury, death, and/or property damage. Consult your local fire marshal or insurance agency to determine the classification of the building to be heated.

- ALL heaters must be directly **vented outdoors**; **NO EXCEPTIONS!** Never vent exhaust products indoors.
- Installation of exhaust venting must comply with the instructions, drawings, and installation notes provided in this section.

### DIRECT OUTDOOR VENTING

- Exhaust venting may be accomplished by passing flue products through piping in the roof or wall as shown below.
- An inlet air roof venting cap (roof) or inlet air box (wall) must be located at least (3) three feet (1m) away from any vent termination and in a manner preventing blockage by snow.
- Components used to exhaust vent outdoors, when supplied by others, must be identical to those specified in this manual and be Metalbestos brand or equal. **NO SUBSTITUTIONS.**
- Use single wall 4" (10.2cm) I.D. galvanized metal pipe of 26 gauge (.018" or 0.46mm) for exhaust vent piping.
- Use RTV silicone adhesive sealant liberally at all vent pipe joints.
- Use (3) three #6 sheet metal screws per vent pipe joint.
- For all systems, total linear (straight) pipe run must not exceed (35) thirty-five feet (11m) within the building.
- A 90-degree elbow is equivalent to (10) ten linear feet (3m). No more than (2) two 90-degree elbows are permitted.
- Allow 18" (46cm) clearance from single wall metal pipe to combustible materials throughout the entire length of exhaust vent piping.
- Where a single wall metal pipe passes through a wall/roof of combustible material, a minimum 2" (5.1cm) clearance non-combustible ventilated metal thimble (not supplied) **MUST** be installed in wall/roof at the point of passage. If thimble is not used, all combustible material **MUST** be removed a minimum of 18" (46cm) in all directions from the metal pipe.
- Heater must not be vented in between buildings less than (10) ten feet (3m) apart or above public walkways, doors or windows.

### IMPORTANT

- **DO NOT** use collapsible material such as dryer duct as a substitute for single wall galvanized pipe. It will melt and/or restrict airflow from the burner causing improper operation.
- Exhaust vent piping must be well supported since additional stress may result due to expansion during heater operation.
- **NEVER** vent into a chimney or use a draft hood, flue collar, or any other device in the exhaust venting of this heater!
- A minimum of (3) three feet (1m) is required between the inlet air cap and the nearest vertical vent terminal on a roof.
- The use of double wall 'B' vent pipe inside the building is limited to equipment with neutral or negative internal pipe pressure. It is not recommended for use with this heater.
- Each vent pipe connecting joint **MUST** be sealed to prevent hot flue gas leakage into the building.
- See **OVERVIEW DRAWINGS** section for more venting information.

### THRU-THE-WALL OR ROOF

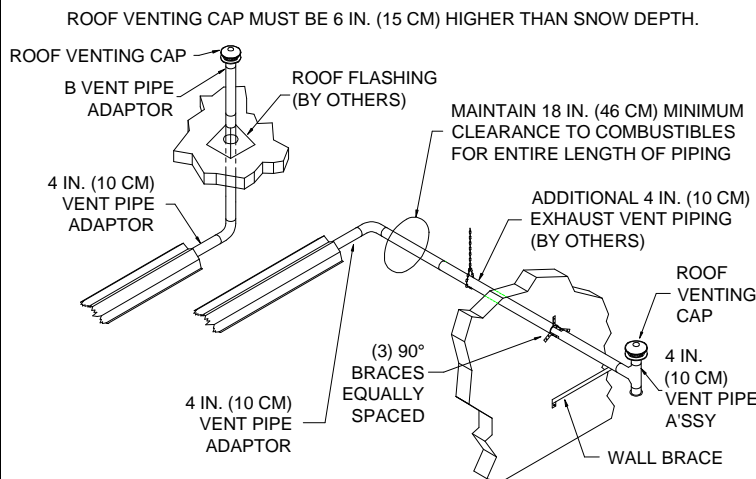

- Do not install exhaust vent cap under eaves.

### EXHAUST VENT DISTANCE FROM:

	BELOW Inches (cm)	BESIDE Inches (cm)	ABOVE Inches (cm)
Door	N/A	48 (122)	N/A
Window	48 (122)	12 (30)	N/A
Gravity Air Inlet	N/A	N/A	12 (30)
Forced Air Inlet Within 10 ft. (3m)	N/A	N/A	36 (91)
Grade	N/A	N/A	12 (30)
Gas Meters & Electric Meters, Regulators & Relief Valves	N/A	48 (122)	N/A

# ELECTRICAL SUPPLY AND THERMOSTATIC CONTROL

ELECTRICAL SUPPLY	120 VAC SUPPLY & 120 VAC THERMOSTATIC CONTROL
<ul style="list-style-type: none"> <li>Voltage: 120VAC - 1 phase - 60 Hz.</li> <li>Maximum Amps: 3.0 (1.47 actual full load)</li> <li>Flame safety: Electronic.</li> <li>Ignition: Direct Spark.</li> <li>Wiring must conform to the latest edition of the National Electric Code (ANSI/NFPA 70) or local code legally authorized.</li> <li>Electrical power takeoff must be connected to a separately fused circuit with a disconnect or a circuit breaker, and must be properly polarized and grounded to the heaters power cord. The heater control is polarity sensitive and will not operate properly if the electrical supply is not wired correctly.</li> <li>Do not run wiring over the heaters or in direct view of radiant heat.</li> <li>If any of the wiring supplied must be replaced use type 16 AWG (1.0mm<sup>2</sup>), or equivalent with 2/64" (.08cm) insulation and a minimum insulation temperature of 302°F (150°C).</li> </ul>	<p style="text-align: center;">PROPER GROUNDING AND POLARITY ARE ESSENTIAL TO THE SAFE OPERATION OF THE HEATER.</p> <p style="text-align: center;">NOTE: ALL COMPONENTS SUPPLIED BY OTHERS.</p>

WARNING	120 VAC SUPPLY & 24 VAC THERMOSTATIC CONTROL
---------	--

<ul style="list-style-type: none"> <li><b>ELECTRICAL GROUNDING INSTRUCTIONS.</b> This heater is equipped with a three-prong (grounding) plug for your protection against shock hazard and should be plugged directly into a properly grounded three-prong receptacle. <b>DO NOT</b> cut or remove the grounding prong from this plug.</li> </ul>	<p style="text-align: center;">PROPER GROUNDING AND POLARITY ARE ESSENTIAL TO THE SAFE OPERATION OF THE HEATER.</p> <p style="text-align: center;">NOTE: ALL COMPONENTS SUPPLIED BY OTHERS.</p>
<p style="text-align: center;"><b>IMPORTANT</b></p> <ul style="list-style-type: none"> <li>The Residential Garage Heater <b>MUST</b> be controlled by a thermostat, timer, or other automatically operated device.</li> </ul>	
<p style="text-align: center;"><b>GENERAL INSTALLATION NOTES</b></p> <ul style="list-style-type: none"> <li>Locate the thermostat as specified in the heating plan.</li> <li>If it is not in the heating plan, follow the instructions provided with the thermostat.</li> <li>If instructions are not provided with the thermostat, locate it 4 to 5 feet (120 to 150cm) above the floor where it will not be directly affected by the heat from the heater, outside drafts, or the sun.</li> </ul>	

# OPERATION AND SHUTDOWN

SEQUENCE OF OPERATION	WIRING CONNECTION DIAGRAM
<ul style="list-style-type: none"> <li>Thermostat calls for heat.</li> <li>120 VAC is applied to the blower and validation light PL-1 indicates power is ON.</li> <li>Air flow switch closes contacts after it senses an increase in air pressure due to fan reaching operational speed.</li> <li>Validation light PL-2 indicates combustion air supply and exhaust venting backpressure is normal.</li> <li>Ignition Detection Control (IDC) is turned on and begins a pre-purge time period.</li> <li>A spark is developed at the igniter and the gas valve is opened to the first step of its two step operation.</li> <li>Burner ignites and 5 seconds later the gas valve steps up to its operating position. DC electrical current flows from sensing electrode through flame to ground.</li> <li>IDC senses flame presence, turns OFF spark, gas continues flowing through valve.</li> <li>Validation light PL-3 indicates normal burner operation.</li> <li>During first trial-for-ignition period or upon any flame outage at sensing electrode, the IDC responds and begins sparking within 0.8 seconds. A 15-second trial-for-ignition period begins to re-light the burner. If flame is re-established, normal operation resumes. If the burner does not light after first try, the inter-purge sequence is completed between trials to re-light the burner. If the burner fails to light (10DX-117) or after third trial (35-725), IDC will de-energize the valve and go into lockout mode.</li> <li>For lockout recovery, reset thermostat below ambient temperature or disconnect electrical power supply for five (5) seconds.</li> <li>If the flame does fail during ignition or normal operation, it is detected by the flame sensor rod, and the IDC then closes the gas valve locking out the system until the thermostat is cycled to the OFF position.</li> <li>When the thermostat is satisfied, the whole system is de-energized until another call for heat.</li> <li>When installing or servicing this heater, wait at least 5 minutes between attempts for ignition.</li> </ul>	<p style="text-align: center;">If any of the original wire as supplied with the appliance must be replaced, it must be replaced with wiring material having a temperature rating of at least 302°F (150°C) and shall have a minimum size of 16 AWG (1.0mm<sup>2</sup>).</p> <p style="text-align: right;">115V.-1PH.-60HZ.</p> <p style="text-align: center;">□ - WIRE NUT SYMBOL</p> <p style="text-align: center;">HIGH VOLTAGE LEAD WIRE</p>
<p style="text-align: center;"><b>SHUTDOWN</b></p> <ul style="list-style-type: none"> <li>To shutdown the heater for <b>a week or less</b>, switch off the electrical supply to the heater.</li> <li>To shutdown the heater for <b>more than one week</b>, switch off the electrical supply to the heater and turn off the gas supply at the gas isolation valve.</li> </ul>	<p style="text-align: center;">If any of the original wire as supplied with the appliance must be replaced, it must be replaced with wiring material having a temperature rating of at least 302°F (150°C) and shall have a minimum size of 16 AWG (1.0mm<sup>2</sup>).</p> <p style="text-align: center;">120V.-1PH.-60HZ.</p> <p style="text-align: center;">CHASSIS GROUND</p>

# GAS SUPPLY AND GAS PRESSURE

GAS SUPPLY PIPING	INLET GAS PRESSURE																																
<ul style="list-style-type: none"> <li>Gas piping must be installed in accordance with local codes and/or the National Fuel Gas Code, ANSI Z223.1 / NFPA 54-latest edition.</li> <li>All pipe connections must have pipe joint compound, resistant to LP/propane gas action.</li> <li>Piping must have drip leg and a ground joint union.</li> <li>Local codes may require shut-off cock ahead of the drip leg.</li> <li>Use only agency approved flexible gas connector furnished with heater. See WARNING.</li> <li>Use swing or swivel joint in addition to rigid piping if local codes prohibit use of a flexible gas connector.</li> <li>Installer provide 1/8" NPT plugged tapping for inlet test point connection immediately upstream of gas connection to heater.</li> <li>Isolate regulators, flexible gas connectors, and heaters during high-pressure leak testing.</li> <li>All gas lines must be purged of air before startup.</li> </ul>	<ul style="list-style-type: none"> <li>Inlet gas pressure must be measured on the inlet side of the valve at the inlet test point (IP). Remove plug from the inlet test point, connect to manometer.</li> <li>Inlet gas pressure must conform to the following:                             <table style="margin-left: 40px; border-collapse: collapse;"> <tr> <th colspan="2" style="text-align: center; border-bottom: 1px solid black;"><b>MINIMUM</b></th> </tr> <tr> <td style="text-align: left; border-right: 1px solid black; padding-right: 10px;"><i>GAS TYPE</i></td> <td style="padding-left: 10px;"><i>INLET PRESSURE</i></td> </tr> <tr> <td style="border-right: 1px solid black; padding-right: 10px;">Natural</td> <td>6" WC (15 cm WC)</td> </tr> <tr> <td style="border-right: 1px solid black; padding-right: 10px;">LP/Propane</td> <td>11" WC (28 cm WC)</td> </tr> <tr> <th colspan="2" style="text-align: center; border-bottom: 1px solid black;"><b>MAXIMUM</b></th> </tr> <tr> <td style="text-align: left; border-right: 1px solid black; padding-right: 10px;"><i>GAS TYPE</i></td> <td style="padding-left: 10px;"><i>INLET PRESSURE</i></td> </tr> <tr> <td style="border-right: 1px solid black; padding-right: 10px;">Natural</td> <td>14" WC (35 cm WC)</td> </tr> <tr> <td style="border-right: 1px solid black; padding-right: 10px;">LP/Propane</td> <td>14" WC (35 cm WC)</td> </tr> </table> </li> </ul>	<b>MINIMUM</b>		<i>GAS TYPE</i>	<i>INLET PRESSURE</i>	Natural	6" WC (15 cm WC)	LP/Propane	11" WC (28 cm WC)	<b>MAXIMUM</b>		<i>GAS TYPE</i>	<i>INLET PRESSURE</i>	Natural	14" WC (35 cm WC)	LP/Propane	14" WC (35 cm WC)																
<b>MINIMUM</b>																																	
<i>GAS TYPE</i>	<i>INLET PRESSURE</i>																																
Natural	6" WC (15 cm WC)																																
LP/Propane	11" WC (28 cm WC)																																
<b>MAXIMUM</b>																																	
<i>GAS TYPE</i>	<i>INLET PRESSURE</i>																																
Natural	14" WC (35 cm WC)																																
LP/Propane	14" WC (35 cm WC)																																
IMPORTANT																																	
<ul style="list-style-type: none"> <li>Inlet gas pressure at inlet test point (IP) cannot be more than 14 inches of <b>Water Column (WC)</b> (35 cm WC) (1/2 PSI), confirmed by actual field test. (Heater on or off).</li> </ul>																																	
WARNING	HIGH GAS PRESSURE																																
<ul style="list-style-type: none"> <li>Connector must be installed in a "D" configuration. Use only the 24" (61 cm) or 36" (91 cm) long connector of 1/2" (13 mm) nominal ID that was furnished with the heater.</li> <li>Stress from expansion and contraction of heater may cause excessive wear on the gas connection.</li> <li>For a heater 20 feet (6.1 m) long, heater tubes can expand up to 1.1" (28 mm).</li> <li>It is important to maintain dimensions on drawing below.</li> </ul>	<ul style="list-style-type: none"> <li>When inlet gas pressure is greater than 14 in. WC (35 cm WC) a positive lockout type high-pressure regulator must be installed in the gas line ahead of the heater.</li> <li>High-pressure regulators will <b>NOT</b> turn off the flow of gas.</li> <li>Always check local codes for gas venting requirements for high-pressure regulators.</li> <li>An over-pressure protection device (OPD) may be required in certain jurisdictions.</li> </ul>																																
MANIFOLD GAS PRESSURE																																	
<ul style="list-style-type: none"> <li>Set inlet pressure first. Fluctuations in inlet pressure can alter manifold pressure coming out of the gas valve.</li> <li>See drawing below for manifold pressure adjustment location.</li> <li>Loosen set screw, or remove plug form manifold test point (MP); connect to manometer.</li> <li>Remove the slotted cap screw covering the manifold adjustment.</li> <li>Turn adjustment screw clockwise to increase pressure or counterclockwise to decrease pressure.</li> <li><b>Manifold Pressure setting is 3.5" WC (8.9 cm WC).</b></li> </ul>																																	
GAS PRESSURE MEASUREMENTS																																	
<ul style="list-style-type: none"> <li>Use only a water or red oil manometer to make measurements --- <b>NOT A DIAL GAUGE.</b></li> <li>Make measurements and adjustments when this heater and <b>ALL</b> other gas burning equipment connected to the same gas meter are operating at maximum capacity.</li> </ul>																																	
GAS CONNECTOR – CORRECT POSITIONS																																	
	<table border="1" style="width: 100%; border-collapse: collapse;"> <thead> <tr> <th style="text-align: center;">Item</th> <th style="text-align: center;">Description</th> </tr> </thead> <tbody> <tr><td style="text-align: center;">A</td><td>Heater movement</td></tr> <tr><td style="text-align: center;">B</td><td>Gas supply nipple must be parallel to heater movement</td></tr> <tr><td style="text-align: center;">C</td><td>Hard piping</td></tr> <tr><td style="text-align: center;">D</td><td>Flexible gas connector</td></tr> <tr><td style="text-align: center;">E</td><td>3" (7.62 cm) maximum displacement</td></tr> <tr><td style="text-align: center;">F</td><td>12" (30 cm)</td></tr> <tr><td style="text-align: center;">G</td><td>Vertical (as shown at left) – end view</td></tr> <tr><td style="text-align: center;">H</td><td>Alternate positions okay – end view</td></tr> <tr><td style="text-align: center;">J</td><td>Gas cock shut-off (by others)</td></tr> <tr><td style="text-align: center;">K</td><td>Drip leg</td></tr> <tr><td style="text-align: center;">L</td><td>Regulator required when pressure exceeds 14" (35 cm) WC (by others)</td></tr> <tr><td style="text-align: center;">IP</td><td>Installer provide inlet test point</td></tr> <tr><td style="text-align: center;">MP</td><td>Manifold test point</td></tr> <tr><td style="text-align: center;">RA</td><td>Robert Shaw or Sit valve manifold pressure adjustment</td></tr> <tr><td style="text-align: center;">WA</td><td>White Rodgers valve manifold pressure adjustment</td></tr> </tbody> </table>	Item	Description	A	Heater movement	B	Gas supply nipple must be parallel to heater movement	C	Hard piping	D	Flexible gas connector	E	3" (7.62 cm) maximum displacement	F	12" (30 cm)	G	Vertical (as shown at left) – end view	H	Alternate positions okay – end view	J	Gas cock shut-off (by others)	K	Drip leg	L	Regulator required when pressure exceeds 14" (35 cm) WC (by others)	IP	Installer provide inlet test point	MP	Manifold test point	RA	Robert Shaw or Sit valve manifold pressure adjustment	WA	White Rodgers valve manifold pressure adjustment
Item	Description																																
A	Heater movement																																
B	Gas supply nipple must be parallel to heater movement																																
C	Hard piping																																
D	Flexible gas connector																																
E	3" (7.62 cm) maximum displacement																																
F	12" (30 cm)																																
G	Vertical (as shown at left) – end view																																
H	Alternate positions okay – end view																																
J	Gas cock shut-off (by others)																																
K	Drip leg																																
L	Regulator required when pressure exceeds 14" (35 cm) WC (by others)																																
IP	Installer provide inlet test point																																
MP	Manifold test point																																
RA	Robert Shaw or Sit valve manifold pressure adjustment																																
WA	White Rodgers valve manifold pressure adjustment																																
GAS CONNECTOR – INCORRECT POSITIONS																																	
CAUTION																																	
<p>Excessive torque on the burner gas inlet pipe or manifold may cause damage to burner. Always use two (2) wrenches when making pipe connections. Check for leaks with non-corrosive gas leak detection fluid. <b>DO NOT USE FLAMES!</b> Thoroughly rinse with clean water to remove leak detection fluid.</p>																																	



## MAINTENANCE

- **FOR SAFETY REASONS, BEFORE PERFORMING ANY MAINTENANCE, DISCONNECT AND LOCKOUT THE ELECTRICAL SUPPLY, INCLUDING THE THERMOSTAT, BY POSITIVE MEANS.**
- All maintenance and/or repair **MUST** be performed by someone trained and qualified to work on gas and electrical equipment.
- Annual maintenance done prior to the beginning of each heating season is all that is usually necessary.
- In dirty, dusty, or wet atmospheres, it may be necessary to examine and perform needed maintenance at additional times during the heating season. Experience will dictate the frequency.
- Radiant tubes, combustion air ducting, and exhaust venting should be inspected to make sure that: suspension points are secure, tube clamp nuts are tight, heater is level, chains are plumb and taut (except for burner safety chain), vent pipe joints are properly sealed, "S" hooks are crimped closed, there is no excessive exterior buildup of dust or dirt, and make sure there are no restrictions such as bird or insect nests in the combustion air or vent piping or their terminations.
- Reflectors should be inspected to make sure they are clean and secure, as detailed in the INSTALLATION section. If dirty, reflectors should be removed and washed with isopropyl alcohol, Simple Green, or buffed with mild rubbing compound.
- On U-tube systems, the U-bend reflector support nuts should be inspected to make sure they are tight.
- Inspect the inside of the blower housing for excessive dust or dirt buildup on the impeller wheel and make sure the air orifice and the inlet air collar are properly attached. Check that the blower can come up to full speed.
- Remove the cover by removing the 4 sheet metal screws on top of the cover.
- Remove the ignitor by removing **ONLY** the end where the vinyl tubing is attached to the ignitor bracket; the fitting to which the vinyl tubing was connected; the ignition lead wire from the ignition detection control; and the sheet metal screw holding the ignitor bracket to the burner housing wall.
- Remove the ignitor carefully; its' electrodes make a ninety degree turn to the right.
- Clean the ignitor's porcelain insulation and check for cracks and proper gaps (see STARTUP section).
- Within the interior of the burner tube, examine the burner nozzle, primary air holes, main orifice and surrounding area for build up of dust or dirt. Clean if necessary.
- Reinstall the ignitor by following the previous instructions in reverse order.
- Examine the ignition detection control for overheating (warped plastic housing, discoloration, etc.)
- A visual inspection of gas valve, airflow switch, and wiring is adequate.
- Inside each clear vinyl tube used for air flow sensing is a small snubber (aluminum cylinder piece). Visually inspect for cleanliness.
- Clean any surfaces needed and correct any situations found in disrepair.
- Replace the cover and sheet metal screws.
- The blower motor is of the permanently lubricated type and requires no additional lubrication.
- Double check that the area under the heater is kept clear and free from combustible materials, gasoline, and other flammable vapors and liquids.
- Reconnect electrical supply and cycle the heater several times using the thermostat allowing five (5) minutes between cycles for proper operation.
- **WARNING: Do not operate heater with any part bypassed, with any part failed or in any possible situation that may compromise safety. Personal injury, death, and/or property damage could result.**

## TROUBLESHOOTING

<ul style="list-style-type: none"> <li>• Check for symptoms and possible causes in the order presented from the top of this chart to the bottom.</li> <li>• The symptoms and possible causes are in a logical progressive order as in a flow chart.</li> </ul>		
SYMPTOM	POSSIBLE CAUSE	CORRECTIVE ACTION
<b>New installation.</b>	1. Heaters not isolated during high pressure leak testing.	1. Replace combination gas valves on each heater.
	2. All gas lines not completely bled of air.	2. Disconnect flex hose at each heater until gas is present. Connect flex hose and leak test.
	3. Gas supply regulator reversed.	3. Remove and install properly.
	4. Electrical supply line voltage & neutral polarity reversed.	4. Correct electrical supply polarity.
<b>Gas odor.</b>	1. Gas pipe joints loose.	1. Check joints with soap solution, tighten as needed.
<b>Blower / PL-1 light does not come on when system energized.</b>	1. Power supply fuse defective.	1. Replace fuse.
	2. 115 VAC not reaching heater.	2. Check thermostat and wiring and fix.
	3. Blower defective.	3. Replace blower.
<b>Pressure switch does not close / PL-2 light does not come on.</b>	1. Inlet or exhaust piping not the proper size and length. (Refer to manual.)	1. Replace piping as required.
	2. Inlet or exhaust termination fittings not to factory specifications.	2. Replace fittings as required.
	3. Inlet or exhaust blocked.	3. Clear blockage.
	4. Airflow tubing or snubber orifice blocked in one or both tubes.	4. Clear blockage.
	5. Blower wheel dirty or damaged.	5. Clean or repair wheel.
	6. Airflow pressure switch defective.	6. Replace airflow pressure switch.
<b>Ignitor does not spark / PL-3 light does not come on.</b>	1. 115 VAC not reaching the Ignition Detection Control (IDC) due to loose wire or connector.	1. Repair loose wire or connector.
	2. High-voltage wire loose or damaged.	2. Secure high-voltage wire or replace ignitor.
	3. Ignition Detection Control (IDC) defective.	3. Replace IDC box.
<b>Burner does not ignite. (There are three trials-for-ignition before the IDC goes into lockout).</b>	1. Gas supply not turned on.	1. Open all manual gas supply valves.
	2. Ignitor not sparking at the tips.	2. Measure spark gap and adjust gap as necessary to 5/32" [0.156" (3.96mm)].
	3. Ignitor not sparking at correct gap.	3. Replace ignitor.
	4. Gas inlet pressure not correct. (See serial plate). Gas inlet piping not sized correctly.	4. Replace inlet gas piping with correct size pipe.
	5. Gas inlet pressure not correct. (See serial plate). Gas supply regulator not set correctly.	5. Adjust gas supply regulator to set inlet pressure to proper level. (See serial plate).
	6. Gas supply regulator sticking.	6. Replace gas supply regulator.
	7. Combination gas valve not in the ON position.	7. Turn combination gas valve to the ON position.
	8. Ignition Detection Control (IDC) not sending 115VAC to combination gas valve.	8. Replace IDC box.
	9. Combination gas valve defective.	9. Replace combination gas valve.
	10. Combination gas valve outlet (manifold) pressure not correct. (See serial plate).	10. Adjust combination gas valve regulator to set inlet (manifold) pressure to proper level.
	11. Main or sub gas orifice blocked by spider web, etc.	11. Clear blockage.
	12. Gas orifice(s) or air orifice size not correct.	12. Install correct size gas orifice(s) or air orifice.
<b>Spark does not stop when the burner ignites.</b>	1. Power supply not grounded to a true earth ground.	1. Install a true earth ground to the power supply.
	2. Flame sensor wire loose or damaged.	2. Secure flame sensor wire or replace wire harness to IDC box.
	3. Flame signal not at least -17 VDC.	3. Check gas inlet and manifold pressures compared to the possible causes in the previous symptom where the burner does not ignite.
	4. Ignition Detection Control (IDC) is defective.	4. Replace IDC box.
<b>Burner does not stay lit until the thermostat is satisfied.</b>	1. Flame sensor wire is loose or damaged.	1. Replace wire harness to IDC box.
	2. Ground connection to IDC loose.	2. Tighten ground connection to IDC.
	3. Electrical supply line voltage & neutral polarity reversed.	3. Correct electrical supply polarity.
	4. Inlet or exhaust partially blocked.	4. Clear blockage.
	5. Airflow pressure switch erratic or defective.	5. Consult factory or replace airflow pressure switch.
	6. Flame signal not at least -17 VDC.	6. Check gas inlet and manifold pressures compared to the possible causes in the previous symptom where the burner does not ignite.
	7. Ignition Detection Control (IDC) defective.	7. Replace IDC box.
<b>Heater will not turn off.</b>	1. Thermostat defective.	1. Replace thermostat.

THIS PAGE INTENTIONALLY LEFT BLANK

# REPLACEMENT PARTS

## **! WARNING !**

Any substitutions of factory-installed parts without prior written permission may result in unsafe operation, property damage, personal injury, death, voids CSA design certification, and manufacturer's warranty.

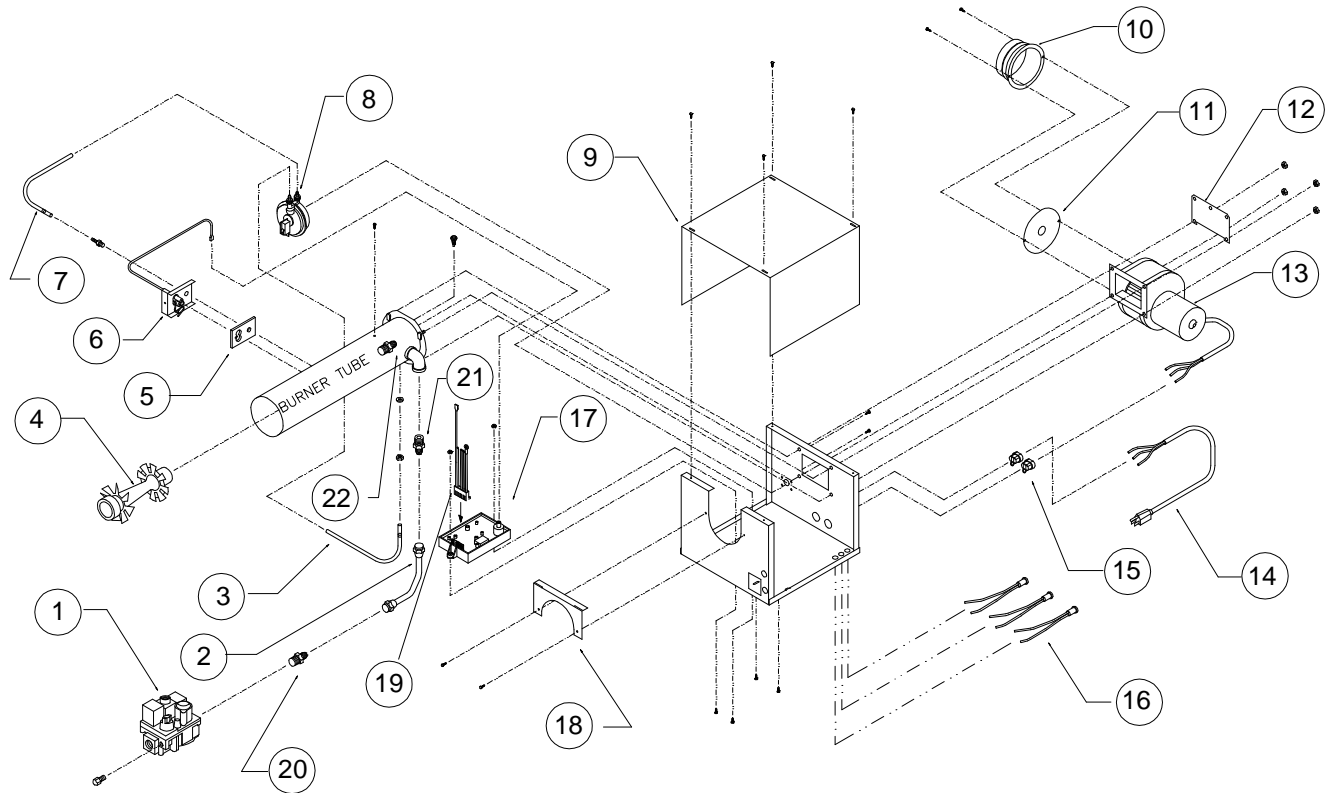

1. Gas valve	12. Safety chain bracket with nuts
2. Gas manifold assembly with fittings	13. Blower motor
3. Air flow switch (combustion) tubing assembly with snubber and fittings	14. 36" (91cm) long power cord with 3-prong grounded plug
4. Burner core	15. Power cord strain relief bushing
5. Ignitor gasket	16. System validation light
6. Ignitor	17. Ignition detection control
7. Air flow switch (exhaust) tubing assembly with snubber and fittings	18. Burner tube holding bracket with screws
8. Air flow switch	19. Wire harness assembly
9. Burner cover	20. Gas manifold fitting (at valve)
10. Inlet combustion air collar	21. Gas sub orifice
11. Air orifice plate	22. Gas main orifice (located inside of burner tube)

**Due to continuous product improvement, please provide model number and serial number prior to ordering replacement parts to assure safe repairs and maintenance.**

## U-TUBE INSTALLATION

- A heater may be installed in a U-Tube with its radiant tubes horizontal or with the heat exchanger angled above the combustion chamber as illustrated by the drawings below.
- When radiant tubes are horizontal, reflectors (except at the U-bend) may be individually rotated from 0 to 45 degrees. (NOTE: the U-bend reflector cannot be rotated.)

### HORIZONTAL

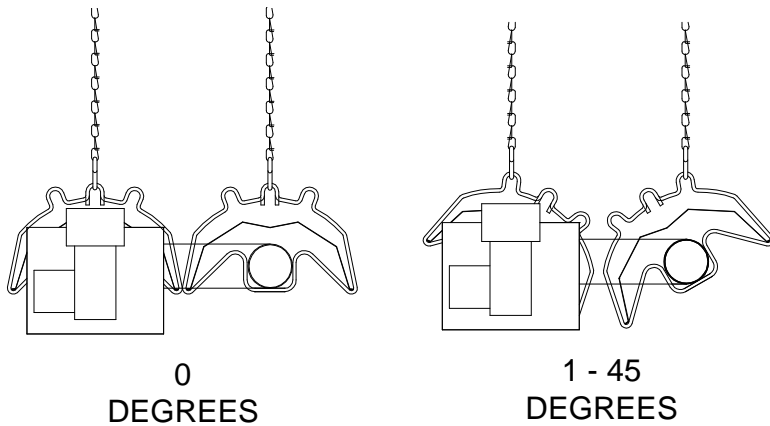

### ANGLED

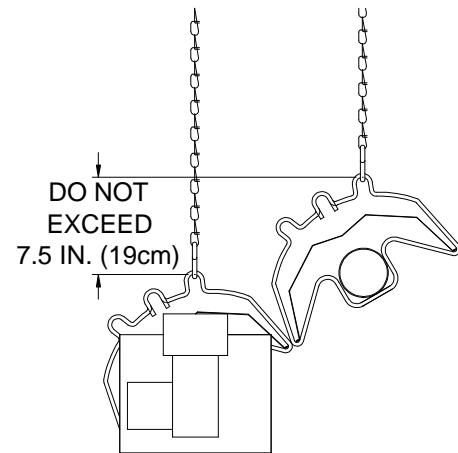

### BASIC SUSPENSION ARRANGEMENT

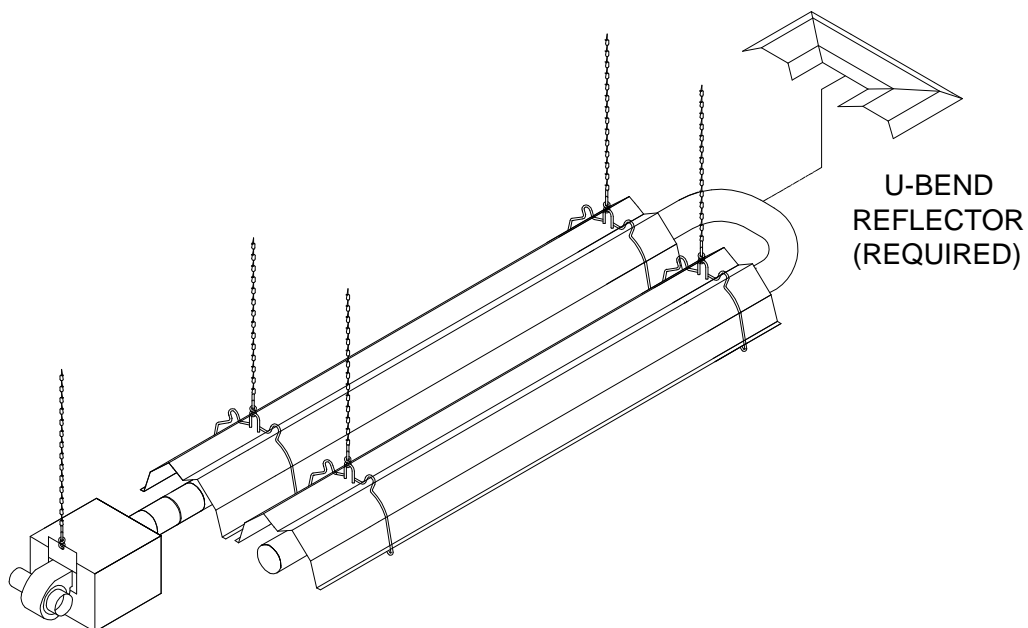

## U-BEND REFLECTOR INSTALLATION

### WARNING

**NEVER** operate the U-tube heater **WITHOUT** the U-bend reflector assembly installed. Unsafe operation, property damage, personal injury, and/or death could result!

### U-TUBE REFLECTOR ARRANGEMENT

ITEM NO.	QTY. NO.	DESCRIPTION
1	1	U-BEND REFLECTOR ASSEMBLY
2	1	U-TUBE
3	2	MINERALAC #8 PIPE HANGER
4	4	5/16-18NC HEX NUT
5	4	5/16" SPLIT LOCK WASHER
6	4	5/16" FLAT WASHER

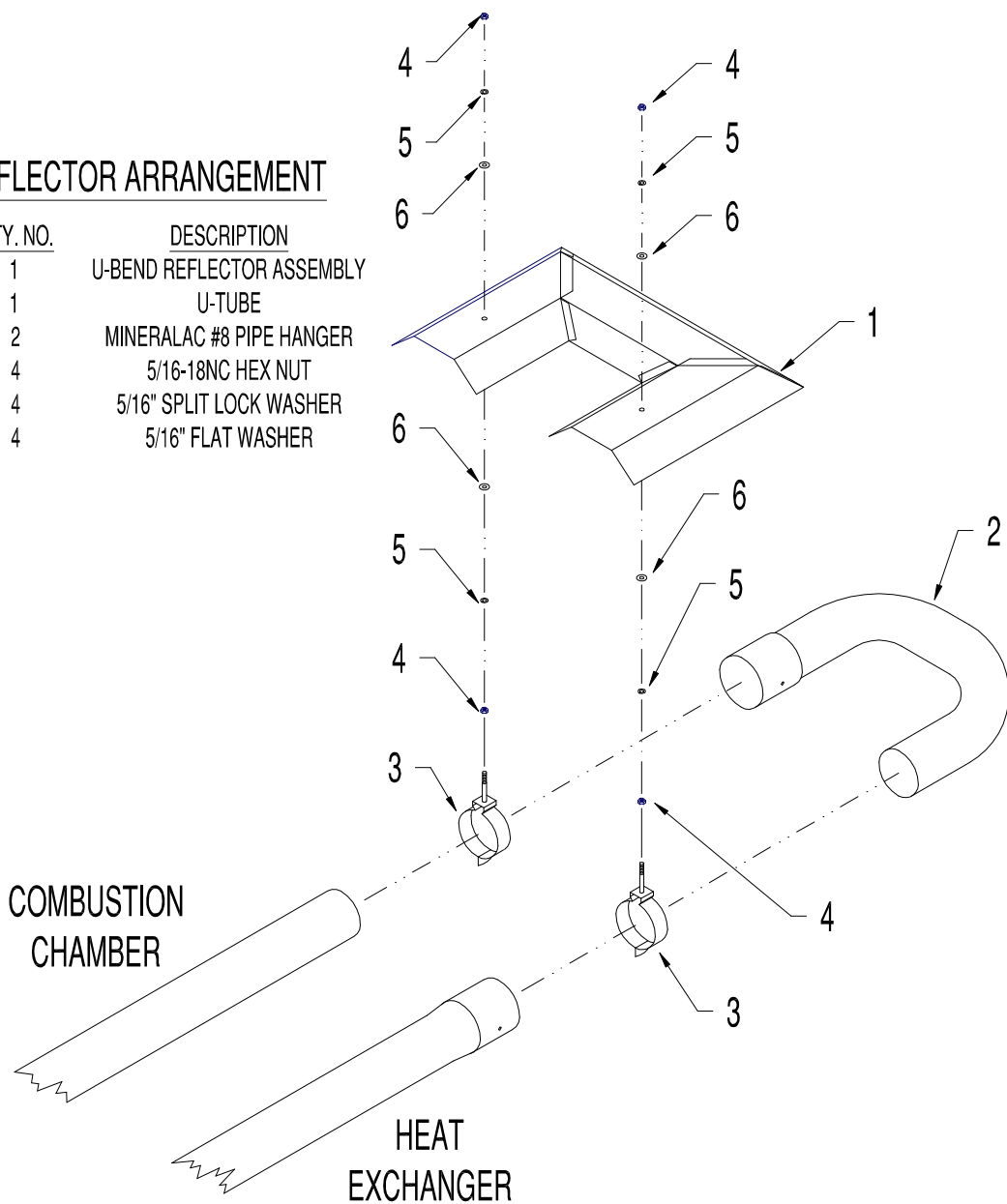



### INSTRUCTIONS

1. Slide pipe hangers (Item no. 6) over U-bend (Item no. 2).
2. Install Items no. 4, 5, and 6 onto the pipe hanger's stud.
3. Place U-bend reflector assembly (Item no. 1) over studs.
4. Install Items no. 4, 5, and 6 over the stud on top.
5. Position U-bend with reflector assembly into combustion chamber and heat exchanger up to the colored indicators.
6. Use (4) four #12 multi-metal self-drilling screws (supplied with U-bend) to fasten U-bend to combustion chamber and heat exchanger.

## BASIC SYSTEM CONFIGURATIONS

- A metal turbulator is always in the LAST 10-foot (3.0m) long tube section.
- LEGEND: L : LP/Propane gas, N : Natural gas.

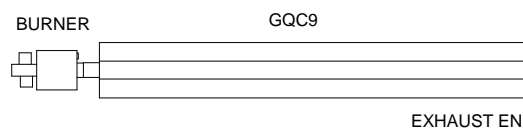
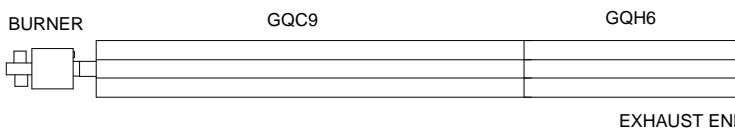
### STRAIGHT TUBE HEATERS

Heater Rating MBTUH (kW)	Tube Length feet (m)	Series	Gas Type	Heater Components
40 (12)	10 (3.1)	A	N/L	
40 (12)	15 (4.6)	A	N/L	
40 (12) 45 (13) 50 (15) 55 (16) 60 (18)	20 (3.1)	A	N/L	

### U-TUBE HEATERS

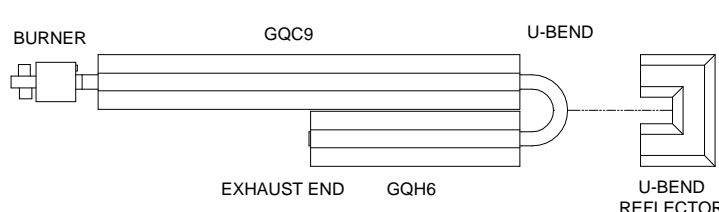
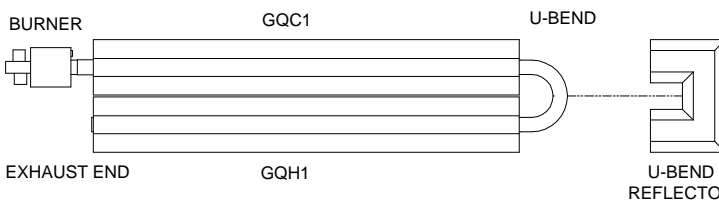
Heater Rating MBTUH (kW)	Tube Length feet (m)	Series	Gas Type	Heater Components
40 (12)	15 (4.6)	A	N/L	
40 (12) 45 (13) 50 (15) 55 (16) 60 (18)	20 (3.1)	A	N/L	

# COMBUSTION CHAMBERS / HEAT EXCHANGERS

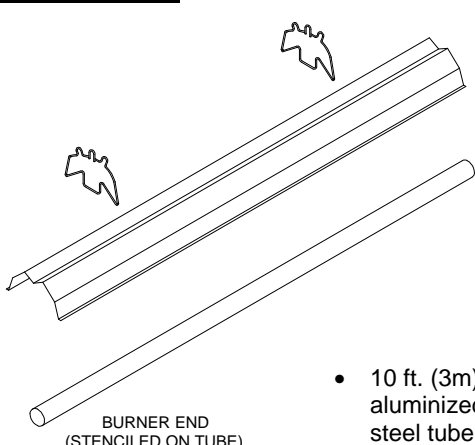
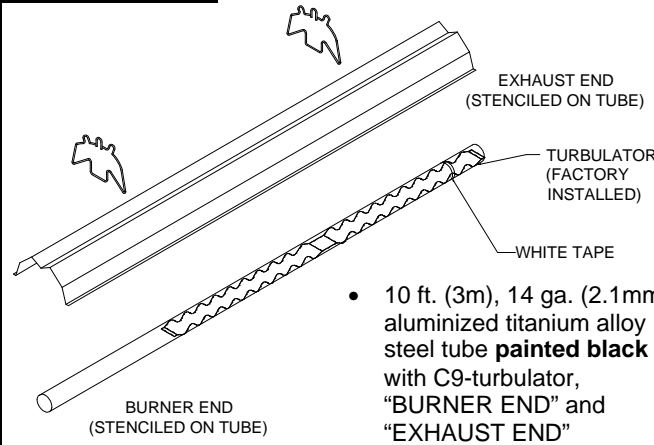
COMBUSTION CHAMBER COMPONENTS	
<p><b>GQC1</b></p> <p>40,000 thru 60,000 BTUH (20 foot unit only) [11.7-17.6kW (6.1m only)]</p>	<p><b>GQC9</b></p> <p>40,000 BTUH (10 and 15 foot units only) [11.7 kW (3 and 4.6m only)]</p>
 <ul style="list-style-type: none"> <li>• 10 ft. (3m), 14 ga. (2.1mm) aluminized titanium alloy steel tube, "BURNER END" stenciled on tube</li> <li>• 10 ft. (3m) aluminum reflector</li> <li>• (2) hanger brackets</li> </ul>	 <ul style="list-style-type: none"> <li>• 10 ft. (3m), 14 ga. (2.1mm) aluminized titanium alloy steel tube <b>painted black</b> with C9-turbulator, "BURNER END" and "EXHAUST END" stenciled on tube</li> <li>• 10 ft. (3m) aluminum reflector</li> <li>• (2) hanger brackets</li> </ul>

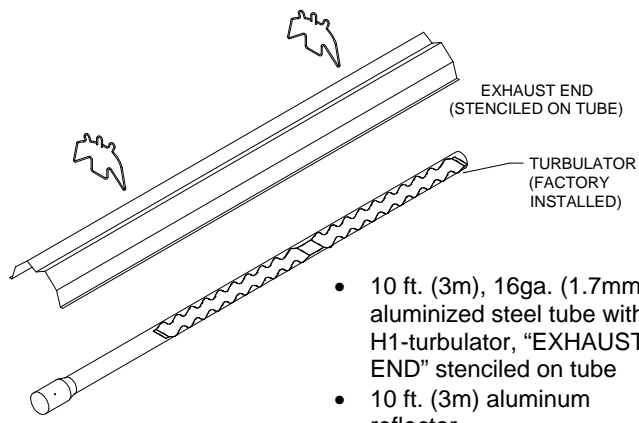
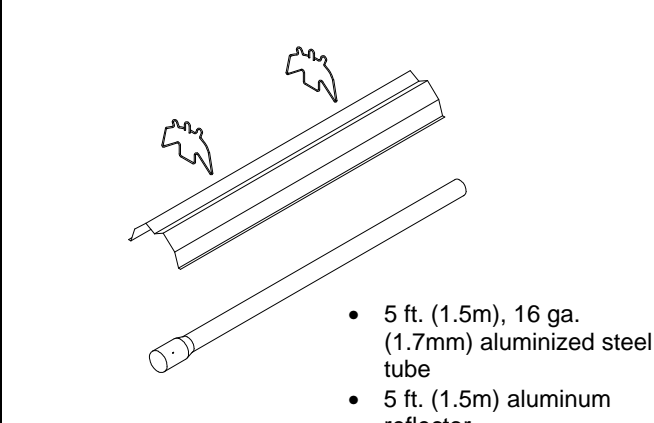
HEAT EXCHANGER COMPONENTS	
<p><b>GQH1</b></p> <p>40,000 thru 60,000 BTUH (20 foot unit only) [11.7-17.6kW (6.1m only)]</p>	<p><b>GQH6</b></p> <p>40,000 BTUH (15 foot unit only) [11.7 kW (3 and 4.6m only)]</p>
 <ul style="list-style-type: none"> <li>• 10 ft. (3m), 16ga. (1.7mm) aluminized steel tube with H1-turbulator, "EXHAUST END" stenciled on tube</li> <li>• 10 ft. (3m) aluminum reflector</li> <li>• (2) hanger brackets</li> </ul>	 <ul style="list-style-type: none"> <li>• 5 ft. (1.5m), 16 ga. (1.7mm) aluminized steel tube</li> <li>• 5 ft. (1.5m) aluminum reflector</li> <li>• (2) hanger brackets</li> </ul>

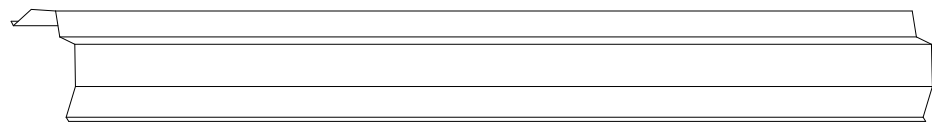
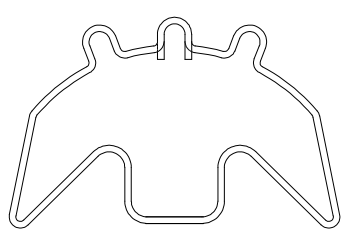
TYPICAL PARTS	
<p>10 foot (3m) reflector [length approximately 119" (302cm)]</p> 	<p>Hanger bracket (Front view)</p> 

# INSTALLATION (1 OF 2)

## CAUTION

- **DO NOT** use gas piping or electrical conduit to provide any type of support for the heater's suspension.
- Means of suspension **MUST BE** able to support twice the weight of the heater, securely fastened to the building's structure, and allow for expansion during its operation.
- Chain for suspension **MUST BE** 12 in. (31cm) minimum in length and be 1/0 TENSO with a minimum working load rating of 200 lbs. (90 kg).
- The "S" hook **MUST BE** Chicago Hardware no. 5 or equal and carry a 70 pound (32kg) maximum load.

**STEP**  
**1**

- Use a taut string in the planning of suspension points to maintain straightness over the length of the system. Make true right angles if 90-degree elbows are used.
- Check the BASIC SYSTEM CONFIGURATIONS section for the general orientation of components matching the model number of your system.
- Identify all components in the COMBUSTION CHAMBERS and HEAT EXCHANGERS sections.
- U-type systems use a 180-degree U-bend. See U-TUBE INSTALLATION section.

**STEP**  
**2**

- Install chain for suspension of tubes and reflectors.
- The suspension points for each 10-foot (3.0m) tube should be a minimum of 4 feet (1.2m) and a maximum of 6 feet (1.8m) apart.
- Use a minimum of 12 in. (31cm) of chain for each suspension point.
- Install a chain to be positioned at the joint between the combustion chamber and the burner.
- Install an additional suspension point at the back of the burner box 17.5 in. (44cm) from the joint between the combustion chamber and the burner.
- Install tube/reflector hangers. Slip one end of the S-hook through the last chain link and the other end through the tube/reflector hanger.
- **IMPORTANT: Crimp both ends of the S-hook closed!**

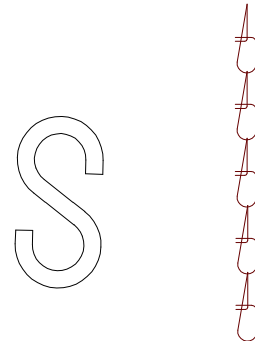

**STEP**  
**3**

- Identify all components in COMBUSTION CHAMBERS and HEAT EXCHANGERS sections of this manual.
- Check the BASIC SYSTEM CONFIGURATIONS section of this manual for the general orientation of components matching the model number of your system.
- Systems fifteen (15) feet (4.6m) or longer require joining together of combustion chamber and heat exchanger tube(s). See TUBE ASSEMBLY TIPS section.
- For U-type systems, a 180-degree u-bend is also used. See U-TUBE INSTALLATION section.
- Slip the burner coupling over the end of the combustion chamber marked "BURNER END".
- Rotate the burner coupling until the two holes on one end of the coupling are each 90 degrees apart from the weld seam on the combustion chamber and seat it against the center stop.
- Use (2) #12 MULTI-METAL Tek screws (supplied with the coupling) to fasten the coupling to the combustion chamber.
- Tubes **MUST NOT** be dragged along the ground or other surfaces which may damage the ends.

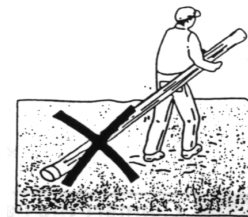
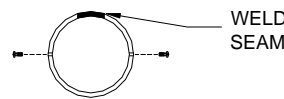
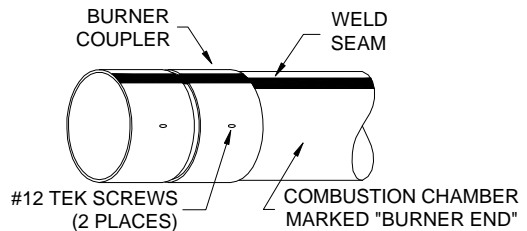

**STEP**  
**4**

- Take this assembly, with the weld seam still facing up, and place the end marked "BURNER END" into the first two suspended hanger bracket assemblies at the point where the burner will eventually be located.
- Place a reflector (gloves are suggested; handle the reflectors with care as not to soil the shiny underside) over the combustion chamber and into the suspended hanger bracket assemblies.

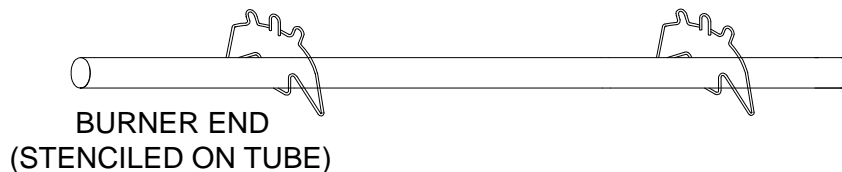

## WARNING

- Heaters shall NOT be installed in living/sleeping areas.

## INSTALLATION (2 OF 2)

<b>STEP</b> <b>5</b>	<ul style="list-style-type: none"> <li>The next heat exchanger tube, with its weld seam up, [for 15 ft. and 20 ft. (4.6 and 6.1 m) systems only] can be put into the respective suspended hanger bracket assemblies.</li> <li>Manually push the flared end of the heat exchanger tube [it has two (2) holes in it] over the swaged end of the combustion chamber as far as you can.</li> <li>[NOTE: The swaged end of the combustion chamber has a colored line 3 in. (7.6 cm) from the end].</li> </ul> <div style="text-align: center; margin-top: 10px;"> </div>
<b>STEP</b> <b>6</b>	<ul style="list-style-type: none"> <li>Go to the swaged end of the heat exchanger tube, and with a 2 pound (0.9kg) hammer and a two (2) in. by four (4) in. (5 cm x 10 cm) block of wood, hit the end of the tube until you have 3 in. (7.6cm) of insertion (the colored line will still be visible).</li> <li><b>Ensure all tubes are straight and level with the weld seam at the top before installing the screws.</b> See the TUBE ASSEMBLY TIPS Section for more information.</li> <li>Tek screw the tube joint connection through the two holes provided in the flared end with (2) two #12 MULTI-METAL Tek screws (supplied with the tube).</li> <li>Place a reflector over the heat exchanger and into the suspended hanger bracket assemblies.</li> </ul> <div style="text-align: center; margin-top: 10px;"> </div>
<b>STEP</b> <b>7</b>	<ul style="list-style-type: none"> <li>Slip the burner's tube into the burner coupler previously installed in Step 4.</li> <li>Once the burner is level, straight and inserted against the center stop, use (2) two #12 MULTI-METAL Tek screws (supplied with the coupling) to fasten the burner to the coupling.</li> <li>Insert the "S" hook of the burner support chain into the center hole of the burner suspension bracket and then crimp the hook closed.</li> </ul> <div style="text-align: center; margin-top: 10px;"> </div>
<b>STEP</b> <b>8</b>	<ul style="list-style-type: none"> <li>Reflectors must not be angle mounted more than 45° from horizontal.</li> </ul> <div style="text-align: center; margin-top: 10px;"> </div>

**WARNING**

- The # 12 MULTI-METAL Tek screws supplied with the coupling **MUST NOT** be substituted with any other type of Tek screw. If you lose them, contact the factory for new ones.

**CAUTION**

- Make sure all chains are plumb and vertical to prevent damage to tubes.

**IMPORTANT**

- Connect the gas supply as instructed in the GAS SUPPLY AND GAS PRESSURE section.
- Connect the electrical supply as instructed in the ELECTRICAL SUPPLY AND THERMOSTATIC CONTROL section.

## PRESS-FIT TUBE ASSEMBLY TIPS (1 OF 2)

Experienced installers have made recommendations to do more connections at ground level before climbing a ladder.

### Most important:

- Do not drag the tubes and dent the connecting ends!
- ALIGN THE WELD SEAMS OF ALL THE TUBES and make sure they are on top when joining tubes!

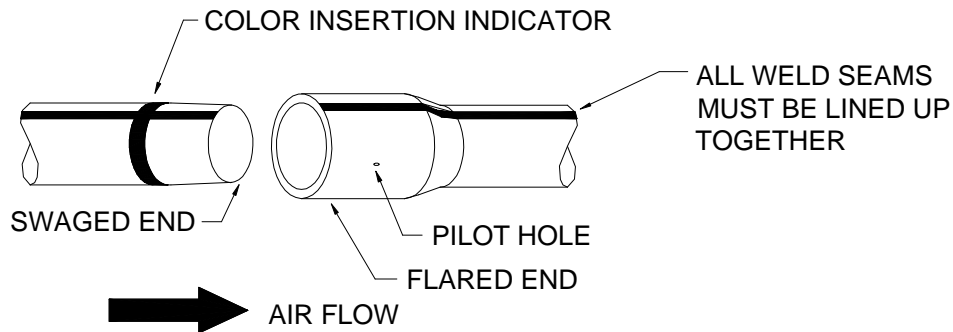

**#1** Place two (2) ten (10) foot (3m) sections on the floor and align the weld seams on top. (Properly orient the “BURNER END”/“EXHAUST END” markings on the combustion and exhaust end tubes).

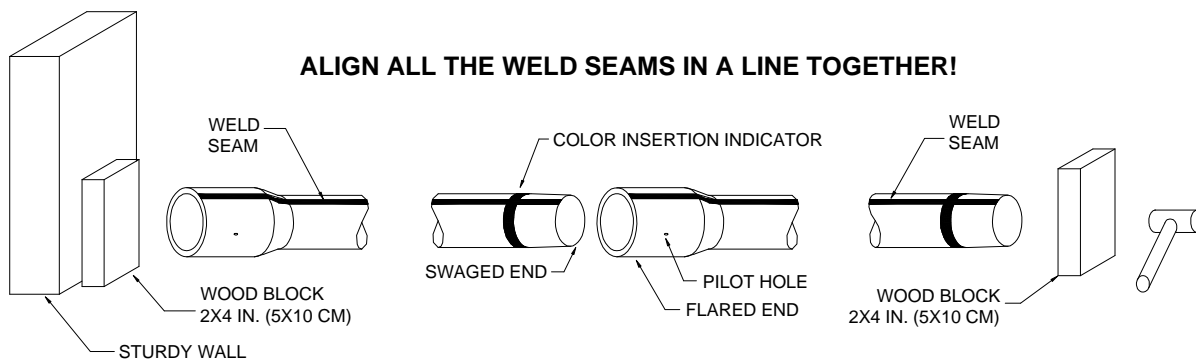

**#2** Position a 2x4 in. (5x10 cm) block of wood on each of the far ends of both tubes.

- One block of wood prevents damage to the connecting end that will be used to tap that tube into the other.
- The other block of wood prevents damage to the other connecting end that is butted up to a nearby sturdy wall.

## PRESS-FIT TUBE ASSEMBLY TIPS (2 OF 2)

**#3** Manually slide the male end of one tube into the female end of the other tube. ALIGN THE WELD SEAMS ON BOTH TUBES TOGETHER. **STRAIGHTEN** the two (2) tubes and proceed to tap one tube into the other by hitting the wooden 2x4 in. (5x10 cm) block, NOT the tube! Continue to tap one tube into the other until the flared end comes up to, but does not cover the color insertion indicator.

### STRAIGHTEN BEFORE DRIVING SCREWS

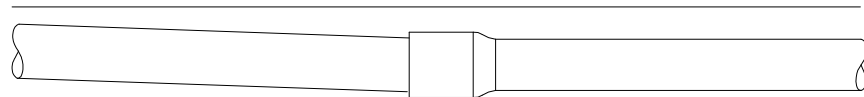

WRONG - NOT STRAIGHT

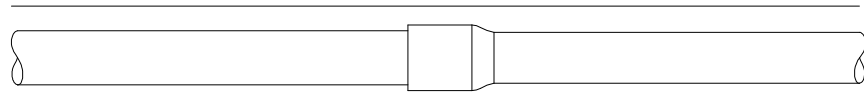

RIGHT - STRAIGHT

**#4** STRAIGHTEN the tubes again BEFORE driving the screws. Ensure all tubes are straight and level with the weld seam on top before installing the screws. Drive with a power tool the two (2) #12 MULTI-METAL Tek screws into the joint and position the four (4) hangers on the twenty (20) foot (6.1m) section.

**#5** Attach a temporary rope or chain to the two (2) outer brackets and hoist the twenty (20) foot (6.1m) section into the air. Align the weld seam on top, level the section, and install the chain on the hangers.

Complete the total installation according to this manual. Use these tips along with the instructions in the INSTALLATION section. Use the U-TUBE INSTALLATION and the U-BEND REFLECTOR INSTALLATION sections as necessary.

**FOR SERVICE OR REPAIR, FOLLOW THESE STEPS IN ORDER:**

**FIRST:** Record the following information

Model No.: \_\_\_\_\_

Unit Serial No.: \_\_\_\_\_

Date of Installation: \_\_\_\_\_

**SECOND:** Contact the Installer

Name \_\_\_\_\_

Address \_\_\_\_\_

Phone \_\_\_\_\_

**THIRD:** Contact the Nearest Distributor

Name \_\_\_\_\_

Address \_\_\_\_\_

Phone \_\_\_\_\_

All rights reserved. No part of this work covered by the copyrights herein may be reproduced or copied by any means: graphic, electronic or mechanical, including photocopying, recording, taping, information storage and retrieval systems without written permission.

Copyright © 2008, Solaronics, Inc.

**Solaronics, Inc.**

**GAS INFRA-RED HEATERS**

704 Woodward Ave., Rochester, Michigan MI 48307 USA

Toll Free: 1-800-223-5335

Phone: 1-248-651-5333

Fax: 1-248-651-0357

E-mail: [sales@solaronicsusa.com](mailto:sales@solaronicsusa.com)

Website: <http://www.solaronicsusa.com>